

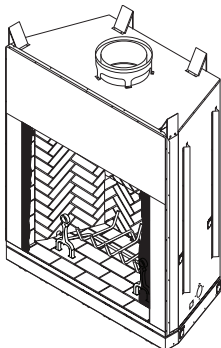

**RESIDENTIAL WOOD BURNING FIREPLACE
OWNER'S OPERATION AND INSTALLATION MANUAL**

**F48H AND VF48H
PLANTATION
48" WOOD BURNING
FIREPLACE
WITH HERRINGBONE
MASONRY BRICK**



We recommend that our products be installed and serviced by professionals who are certified in the U.S. by NFI (National Fireplace Institute).
www.nficertified.org

IF FIREPLACE IS TO BE INSTALLED DIRECTLY ON ANY COMBUSTIBLE MATERIAL, A HEARTH SPACER IS REQUIRED.

SAVE THIS BOOK

This book is valuable. In addition to instructing you on how to install and maintain your appliance, it also contains information that will enable you to obtain replacement parts or accessory items when needed. Keep it with your other important papers.

This fireplace is approved for use as a wood burning fireplace or for use with a vented gas log approved to ANS Z21.60, Z21.84 or RGA 2-72 standards or for use with a vent-free gas log heater approved to ANS Z21.11.2 standard.

This wood burning fireplace complies with UL127-CAN/ULS-S610-M87 standard as a **FACTORY BUILT APPLIANCE**.

FOR CANADA: The authority having jurisdiction (such as the municipal building department, fire department, etc.) should be contacted before installation to determine the need to obtain a permit.

INSTALLER: Leave this manual with the appliance.
CONSUMER: Retain this manual for future reference.

WARNING: Improper installation, adjustment, alteration, service or maintenance can cause injury, property damage or loss of life. Refer to this manual for assistance or additional information. Consult a qualified installer or local distributor.

TABLE OF CONTENTS

Safety Information	2	Brick Installation	11
Specifications	3	Glass Door Installation	15
Fireplace Installation.....	4	Operation and Maintenance Guidelines	16
Venting Installation	5	Replacement and Accessory Parts.....	18
Optional Gas Line Installation.....	10	Technical Service.....	19

SAFETY INFORMATION

IMPORTANT: Check local codes before installing this fireplace.

Before beginning the installation of the fireplace, read these instructions through completely.

- This DESA fireplace and its components are safe when installed according to this installation manual. Unless you use DESA components, which have been designed and tested for the fireplace system, you may cause a fire hazard.
- The DESA warranty will be voided by and DESA disclaims any responsibility for the following actions.
 - a. Modification of the fireplace, components, doors, air inlet system and damper control.
 - b. Use of any component part not manufactured or approved by DESA in combination with a DESA fireplace system.

Proper installation is the most important step in ensuring safe and continuous operation of the fireplace. Consult the local building codes as to the particular requirements concerned with the installation of all factory built fireplaces.

 **WARNING: Do not install a fireplace insert in this box unless the manufacturer's instructions with the insert specifically state this fireplace has been tested for use with this insert.**

This fireplace is not intended to be used as a substitute for a furnace to heat an entire home. Use for supplemental heat only.

FOR YOUR SAFETY

- Do not store or use gasoline or any other flammable vapors or liquids in the vicinity of this or any other appliance.
- Due to high temperatures, the appliance should be located out of traffic and away from furniture and draperies.
- Do not place clothing or other flammable materials on or near the appliance.
- Never leave children unattended when a fire is burning in the fireplace.

 **WARNING: Use solid wood or processed solid fuel fire logs only. When processed wood fuel fire logs are used, do not poke or stir the logs while they are burning. Use only fire logs that have been evaluated for the application in fireplace and refer to fire log warnings and caution markings on packaging prior to use.**

 **WARNING: Always leave glass doors fully opened or fully closed when operating fireplace.**

 **WARNING: If fireplace is to be installed on combustible material, a Hearth Spacer must be used. See *Replacement and Accessory Parts* on page 18.**

SPECIFICATIONS

MODELS F48H AND VF48H

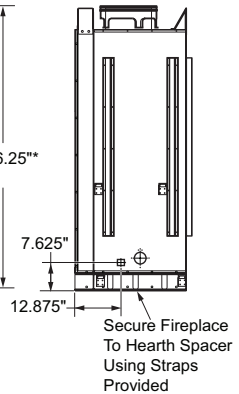
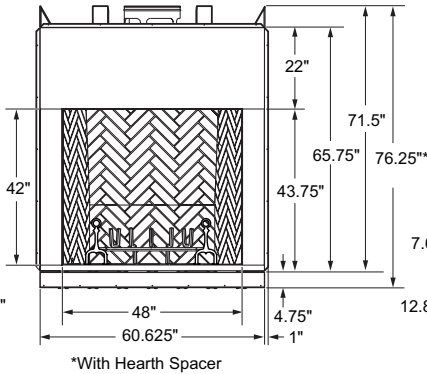
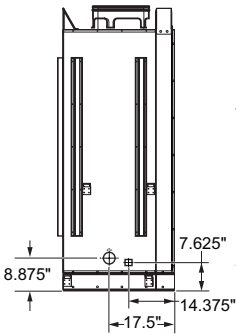
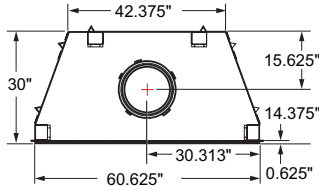
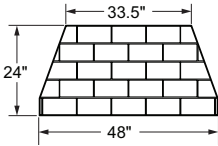
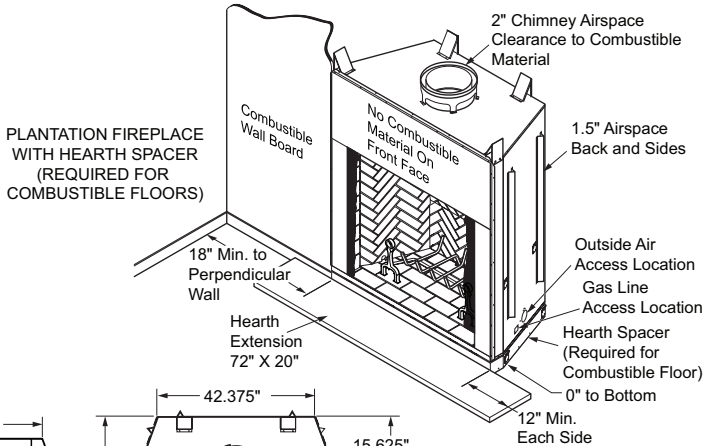
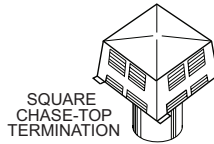

FIREPLACE INSTALLATION

SELECTING LOCATION

To determine the safest and most efficient location for the fireplace, you must take into consideration the following guidelines:

1. The location must allow for proper clearances (see Figures 1 and 2).
2. Consider a location where the fireplace will not be affected by drafts, air conditioning ducts, windows or doors.
3. A location that avoids the cutting of joists or roof rafters will make installation easier.
4. An outside air kit is available with this fireplace (see *Optional Outside Air Kit* on page 6).

MINIMUM CLEARANCE TO COMBUSTIBLES

Back and sides of fireplace	1 1/2" min.*
Front of fireplace	48" min.
Floor**	0" min.
Perpendicular wall to opening	18" min.
Top spacers	0" min.
Mantel clearance	see <i>Mantels</i> , page 5
Chimney outer pipe surface	2" min.

* Not required at nailing flanges

** See step 2 of *Framing*

WARNING: Do not pack required air spaces with insulation or other materials.

Minimum/Maximum Chimney Height

The minimum height of the chimney, measured from the base of the fireplace to the flue gas outlet of the termination, is 16 feet for straight flue or a flue with one elbow set. The maximum distance between elbows is 6 feet. For systems with two elbow sets, the minimum height is 22 feet. The maximum height of any system is 50 feet. This measurement includes the fireplace, chimney sections and the height of the termination assembly at the level of the flue gas outlet (see Figure 15, page 9).

FRAMING

1. Frame the opening for the fireplace using the dimensions shown in Figures 1 and 2.
2. If the fireplace is to be installed directly on carpeting, tile (other than ceramic) or any combustible material including wood flooring, the fireplace must be installed on a hearth spacer designed for use with this fireplace (see *Replacement and Accessory Parts*, page 18).

3. Set the fireplace directly in front of this opening and slide the unit back until the nailing flanges touch the side framing.
4. Check the level of the fireplace and shim with sheet metal if necessary.
5. Before securing fireplace to prepared framing, the ember protector (provided) must be placed between the hearth extension (not supplied) and under the bottom front edge of the fireplace to protect against glowing embers falling through. If the fireplace is to be installed on a raised platform, a Z-type ember protector (not supplied) must be fabricated to fit your required platform height. The ember protector should extend under the fireplace a minimum of 1 1/2". The ember protector should be made of galvanized sheet metal (28 gauge minimum to prevent corrosion).
6. Using screws or nails, secure the fireplace to the framing through flanges located on the sides of the fireplace.

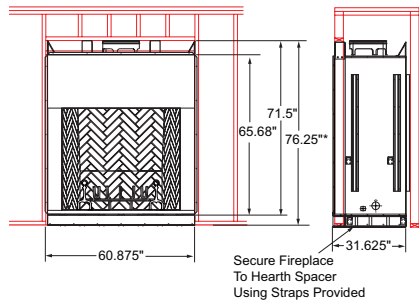

Figure 1 - Framing Dimensions

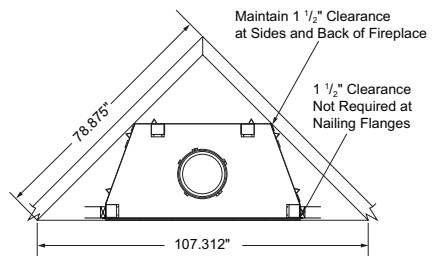

Figure 2 - Corner Installation

FIREPLACE INSTALLATION

Continued

HEARTH EXTENSION

A hearth extension projecting a minimum of 20" in front of and a minimum of 12" beyond each side of the fireplace opening is required to protect combustible floor construction in front of the fireplace. Fabricate a hearth extension using a material which meets the following specifications: a layer of noncombustible, inorganic material having a thermal conductivity of $K=0.84$ BTU IN/FT, HR, F (or less) at 1" thick. For example, if the material selected has a K factor of 0.25, such as glass fiber, the following formula would apply:

$$\frac{0.25}{0.84} \times 1.0" = 0.30" \text{ thickness required}$$

Thermal conductivity "K" of materials can be obtained from the manufacturer or supplier of the noncombustible material. If the hearth extension is to be covered, use noncombustible material such as tile, slate, brick, concrete, metal, glass, marble, stone, etc. Provide a means to prevent the hearth extension from shifting and seal gap between the fireplace frame and hearth extension with a noncombustible material (see Figure 3).

WARNING: Hearth extension is to be installed only as shown in Figure 3.

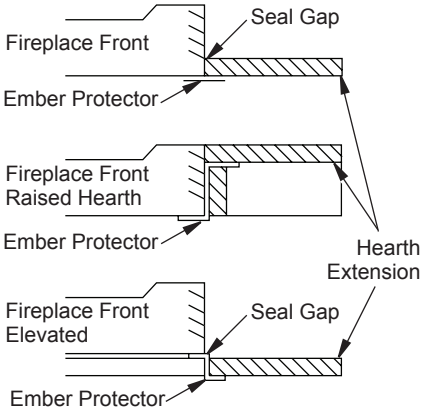

Figure 3 - Hearth Extension

MANTELS

A mantel may be installed if desired (see Figure 4). Woodwork such as wood trims, mantels or any other combustible material projecting from the front face must not be placed within 12" of the fireplace opening. Combustible materials above 12" and projecting more than 1 1/2" from the fireplace must not be placed less than 15" from the top opening of the fireplace (NFPA STD 211, Sec. 7-3.3.3).

Mantels or any other combustible material also may come up to the side edge of the black metal face of the fireplace just as long as the projection from the front face fall within the limit shown in Figure 4.

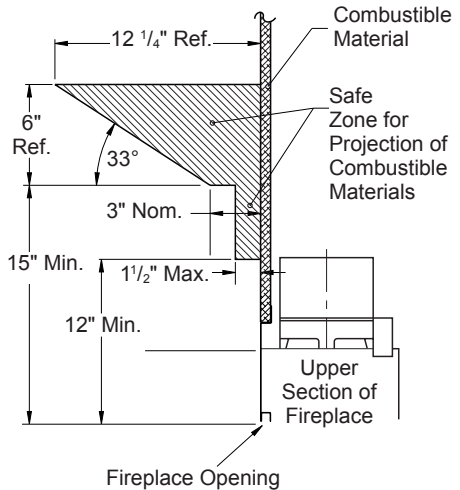

Figure 4 - Mantel Clearances to Combustible Material

VENTING INSTALLATION

OPTIONAL OUTSIDE AIR KIT (MODEL AK4/AK4F)

The installation of an outside air kit should be performed during the rough framing of the fireplace due to the nature of its location. Outside combustion air is accessed through a vented crawl space (AK4F) or through a sidewall (AK4). This fireplace is equipped with a barometric damper which allow outside air to flow into fireplace automatically when needed.

VENTING INSTALLATION

Continued

CAUTION: Combustion air inlet ducts shall not terminate in attic space.

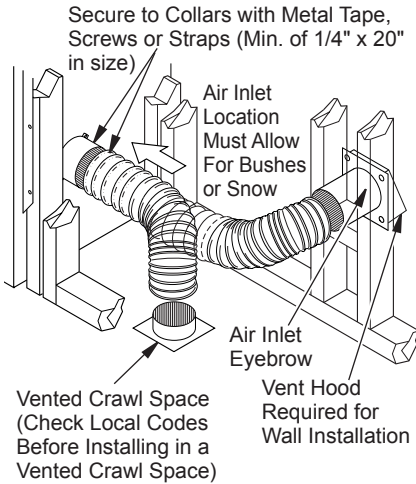

Figure 5 - Outside Air Kit

CHIMNEY PIPE

The DESA chimney system consists of 12", 18", 24", 36" and 48" snap-lock, double-wall pipe segments, planned for maximum adaptability to individual site requirements. Actual lengths gained after fitting overlaps must be taken into consideration (lineal gain) and are given in the lineal gain chart (see Figure 6). Lineal gain is the actual measurable length of a part after two or more parts are connected. For Canada, use chimney parts designated "HT".

WARNING: The opening in the collar around the chimney at the top of the fireplace must not be obstructed. Never use blown insulation to fill the chimney enclosure.

LINEAL GAIN		
PART NO.	DESCRIPTION	GAIN (IN)
48" Plantation	Fireplace	66 1/2"
12-12DM 12-12HT	Pipe Section	10 5/8"
18-12DM 18-12HT	Pipe Section	16 5/8"
24-12DM 24-12HT	Pipe Section	23 5/8"
36-12DM 36-12HT	Pipe Section	34 5/8"
48-12DM 48-12HT	Pipe Section	46 5/8"
RLT-12D RLT-12HT	Round Termination	7 3/4"*
STL-12D	Square Chase-Top with Slip Section	7" to 15"*

* The lineal gain for the terminations is measured to the flue gas outlet height.

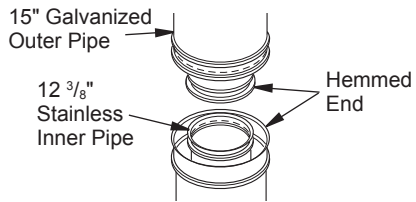

Figure 6 - Lineal Gain

ASSEMBLY AND INSTALLATION OF DOUBLE WALL CHIMNEY SYSTEM

Each double wall chimney section consists of a galvanized outer pipe, a stainless steel inner flue pipe and a wire spacer. The pipe sections must be assembled independently as the chimney is installed. When connecting chimney directly to the fireplace, the inner flue pipe section must be installed first with the lanced side up. The outer pipe section can then be installed over the flue pipe section with the hemmed end up. Press down on each pipe section until the lances securely engage the hem on the fireplace starter. The wire will assure the proper spacing between the inner and outer pipe sections.

Continue to assemble chimney sections as outlined above, making sure that both the inner and outer pipe sections are locked together. When installing double wall snap-lock chimney together, it is important to assure the joint between the chimney sections is locked. Check by pulling chimney upward after locking. The chimney will not come apart if properly locked. It is not necessary to add screws to keep the chimney together (exception, see Figure 9, page 8).

VENTING INSTALLATION

Continued

USING ELBOW OFFSETS (30E-12DM)

1. To achieve desired offset, you may install combinations of 12", 18", 24", 36" and 48" length of double wall pipe (see offset chart and Figure 7).

OFFSET	RISE	CHIMNEY LENGTH				
		12"	18"	24"	36"	48"
4 3/8"	16 3/8"	ELBOW SET ONLY				
9 3/4"	25 1/2"	1				
12 3/4"	30 3/4"		1			
15"	34 3/4"			1		
18"	40"	1	1			
21 1/4"	46 1/4"				1	
23 3/4"	49 1/4"		1	1		
27 3/4"	56 3/4"					1
30"	60 3/4"		1		1	
33"	66"					1
36"	71"		1			1
38 1/4"	75"				2	
41 1/4"	80 1/4"	1	1		1	
45"	86 3/4"				2	
46 3/4"	89 1/2"	1	1			1
51"	97"				1	1
53 1/4"	101"				2	
56 1/4"	106 1/4"					2
59 1/4"	111 1/2"		1		1	1
61 3/4"	115 1/2"	1				2
64 3/4"	120 3/4"		1			2
68 1/4"	127"				2	1
70"	130"	1	1			2
74 1/4"	137 1/2"	1			2	1
76 3/4"	141 1/2"		1		2	1
79 3/4"	146 3/4"				4	

OFFSET CHART (22-50 FT. SYSTEM HEIGHT)

2. Chimney weight above offset rests on return elbow. Straps must be securely nailed to rafters or joists (see Figure 8, details a and b).
3. Maximum length of pipe between supports (return elbow or 12S-12DM) is 6' of angle run. Maximum of two 6' angle run sections per chimney system (see Figure 7).
4. All pipe connections between the offset and return must be secured with two screws on the outer pipe only (see Figure 9, page 8). Do not penetrate the inner stainless.

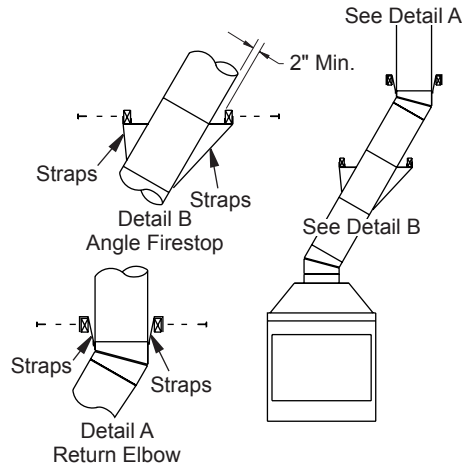

Figure 8 - Ceiling Support Pipe 12S-12DM

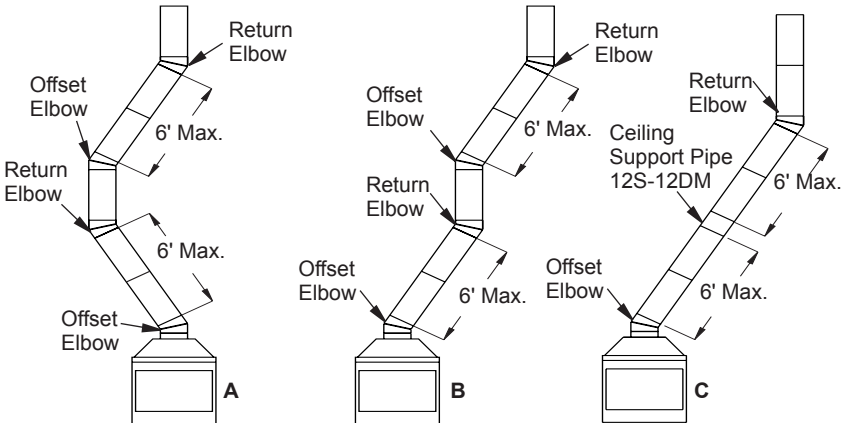

Figure 7 - Typical Offset Terminations

VENTING INSTALLATION

Continued

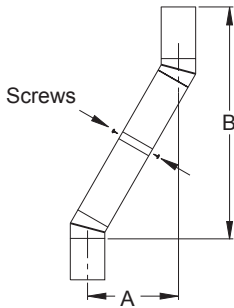

Figure 9 - Elbow Offset

FIRESTOP SPACERS (FS-10)

Firestop spacers are required at each point where the chimney penetrates a floor space. Their purpose is to establish and maintain the required clearance between the chimney and the combustible materials. When the pipe passes through a framed opening into a living space above, the firestop must be placed onto the ceiling from below as shown in Figure 10.

They also provide complete separation from one floor space to another or attic space as required by most codes. When the double wall pipe passes through a framed opening into an attic space, the firestop must be placed into an attic floor as shown in Figure 11.

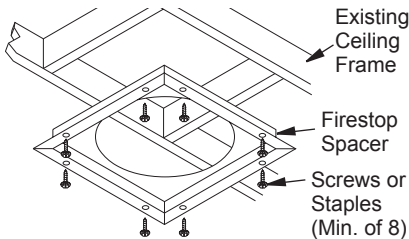

Figure 10 - Firestop Spacer with Living Space Above Ceiling

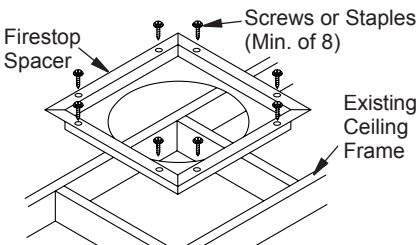
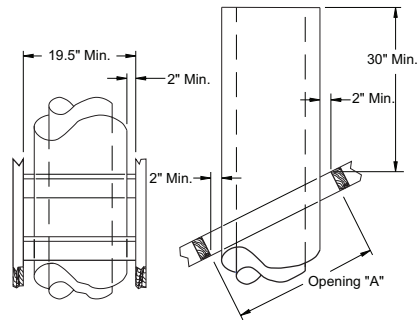

Figure 11 - Firestop Spacer with Attic Space Above Ceiling

PENETRATING THE ROOF

To maintain a 2" clearance to the pipe on a roof with a pitch, a rectangular opening must be cut.

1. Determine the center point through which the pipe will penetrate the roof.
2. Determine the center point of the roof. Pitch is the distance the roof drops over a given span, usually 12". A 6/12 pitch means that the roof drops 6" for each 12" one measure horizontally down from the roof rafters.
3. Use the roof opening chart (Figure 12) to determine the correct opening length and flashing required.
4. Remove the shingles around the opening measured. Cut out this section.
5. Add the next sections of the pipe until the end penetrates the roof line. Check to see that the proper clearances are maintained. Extend chimney by adding sections of double wall pipe until pipe is minimum of 30" above the highest point of the roof cutout. Termination and chimney must extend a minimum of 36" above the highest point where it passes through the roof.



Pitch	Slope	Opening "A" Max.	Used Flashing Model No.
Flat	0°	19.5"	V6F-10DM
0-6/12	26.6°	22"	V6F-10DM
6/12-12/12	45.0°	27"	V12F-10DM

Figure 12 - Roof Opening Measurements

VENTING INSTALLATION

Continued

FLASHING INSTALLATION (V6F-10DM OR V12F-10DM)

Determine the flashing to be used with the roof opening chart. Slide flashing over pipe until base is flat against roof. Replace as many shingles as needed to cover exposed area and flashing base. Secure in position by nailing through shingles (see Figure 13). DO NOT NAIL THROUGH FLASHING CONE.

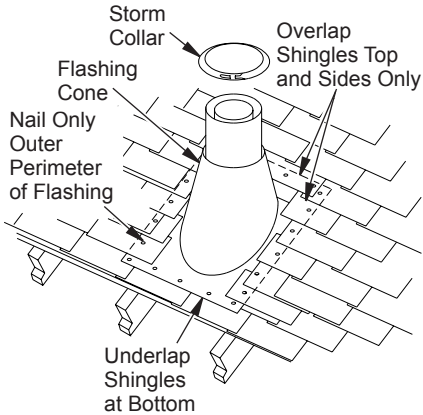

Figure 13 - Flashing Installation

Installing Flashing on a Metal Roof

When installing the flashing on a metal roof, it is required that putty tape be used between the flashing and the roof. The flashing must be secured to the roof using #8 x 3/4" screws and then sealed with roof coating to prevent leakage through the screw holes. A roof coating must also be applied around the perimeter of the flashing to provide a proper seal.

Storm Collar Installation (SC2-1)

Place storm collar over pipe and slide down until it is snug against the open edge of the flashing (see Figure 14). Apply waterproof caulk around the perimeter of the collar to provide a proper seal.

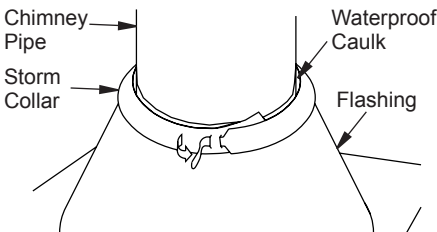

Figure 14 - Storm Collar

Terminations/Spark Arrestor

The fireplace system must be terminated with the listed round top or chase terminations. In any case, refer to the installation instructions supplied with the termination.

CAUTION: Do not seal openings on the rooftop flashing. Follow the installation instructions provided with the termination being used.

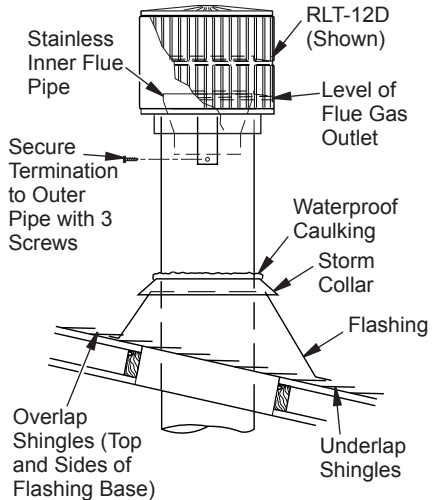

Figure 15 - Termination

CHASE INSTALLATIONS

Instructions for chase installations are included with the chase style termination chosen. In a multiple chase installation, be sure to provide adequate distance between terminations to prevent smoke spillage from one termination to another. Terminations must be separated a minimum of 24" center to center and stacked at a minimum vertical height difference of 18" (see Figure 16, page 10).

Note: If a decorative shroud is to be installed, contact the manufacturer for specifications.

VENTING INSTALLATION

Continued

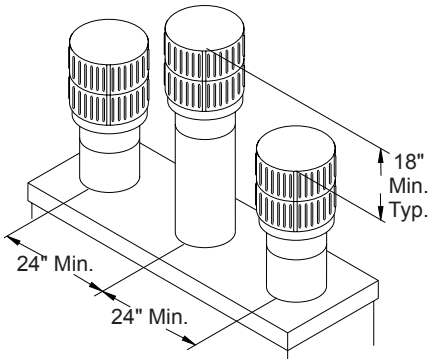

Figure 16 - Multiple Chase Installation

10 FOOT RULE

All flue gas outlet chimney terminations must extend a minimum of 3 feet in height above the highest point where it passes through the roof and must be at least 2 feet above the highest point of the roof that is within a horizontal distance of 10 feet (see Figure 17).

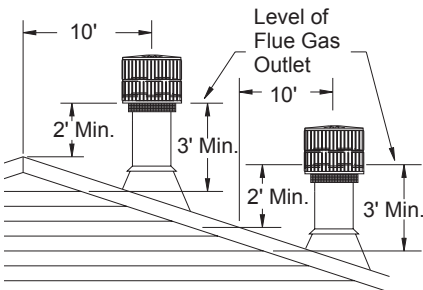

Figure 17 - 10 Foot Rule

FINISHING THE FIREPLACE

Combustible materials, such as wallboard, gypsum board, sheet rock, drywall, plywood, etc. may make direct contact with sides and top around the fireplace face. It is important that combustible materials do not overlap the face itself. Brick, glass, tile or other noncombustible materials may overlap the front face provided they do not obstruct essential openings like louvered slots or any other opening. When overlapping with a noncombustible facing material, use only noncombustible mortar or adhesive.

OPTIONAL GAS LINE INSTALLATION

Gas line hook up should be done by your supplier or a qualified service person. **Note:** Before you proceed, make sure your gas supply is turned off. Use only a 1/2" black iron pipe and appropriate fittings.

1. Remove gas line cover plate located on either side of fireplace and pull out insulation from gas line conduit sleeve. Save insulation for reuse. Replace screws.
2. Run a 1/2" black iron gas line into the fireplace through the rear at gas line conduit sleeve (if using a raised platform, add height). Provide sufficient gas line into fireplace chamber for fitting connection (see Figure 18). **Note:** Secure incoming gas line to wood framing to provide rigidity for threaded end.
3. Repack insulation around gas line and into sleeve opening. Seal any gaps between gas line and refractory knockout hole with refractory cement or commercial furnace cement. Install the gas appliance or cap-off gas line if desired.

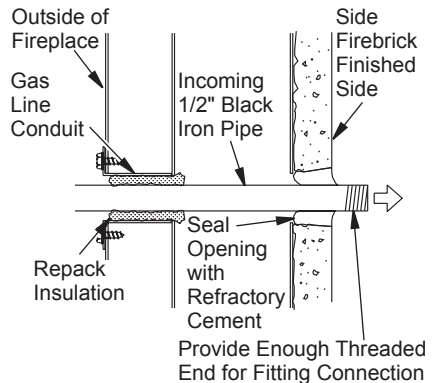

Figure 18 - Gas Line Installation

OPTIONAL GAS LINE INSTALLATION

Continued

⚠ CAUTION: All gas piping and connections must be tested for leaks after the installation is completed. After ensuring that the gas valve is on, apply soap and water solution to all connections and joints. Bubbles forming show a leak. Correct all leaks at once. **DO NOT USE AN OPEN FLAME FOR LEAK TESTING AND DO NOT OPERATE ANY APPLIANCE IF A LEAK IS DETECTED. LEAK TESTING SHOULD BE DONE BY A QUALIFIED SERVICE PERSON.**

⚠ WARNING: Do not operate an unvented gas log set in this fireplace with the chimney removed.

If you install a decorative gas appliance (vented gas log), the decorative gas appliance must comply with the *Standard for Decorative Gas Appliance for Installation in Solid Fuel Burning Fireplaces, ANS Z21.60, Z21.84 or RG 2-72* and shall also be installed in accordance with the *National Fuel Gas Code, ANSI Z223.1/NFPA 54* latest edition.

⚠ WARNING: If the fireplace has been used for wood burning, the firebox and chimney must be cleaned of soot, creosote and ashes by a qualified chimney cleaner. Creosote will ignite if heavily heated.

⚠ WARNING: When using a decorative vented gas log, the damper must be removed or permanently locked in the fully open position and the glass doors must be in the fully open position.

BRICK INSTALLATION

Installation of brick should be done after the fireplace is placed in a permanent location.

The brick housing panels are already installed in the firebox. Each housing is stamped with a letter (full size bricks are not stamped). These letters will help identify the brick when installing (see Figure 19). It is important to install these bricks exactly as instructed. Press the brick firmly into the brick housing until it snaps. The groove line on the side of the brick will come in contact with the flange on the brick housing. This secures the brick into the housing. Smaller bricks may require a small portion of furnace cement applied to back of brick to secure it until grouting has been completed.

The bricks are packaged in five (5) separate boxes. These boxes are labeled by sections of the firebox.

Box #1 - Hearth Panel

Box #2 - Rear Panel, Lower Section

Box #3 - Rear Panel, Upper Section

Box #4 - Right Panel

Box #5 - Left Panel

Install bricks one section at a time starting with hearth panel followed by the rear panel-lower section, rear panel - upper section and then the left and right panels. It is important to install the bricks in sequence. Please note, full size bricks are NOT stamped.

NOTICE: An Ash Lip Kit is available for this fireplace (see *Replacement and Accessory Parts, page 18*). If using Ash Lip Kit, the standard optional glass door kit available for this fireplace can not be installed. If using Ash Lip, obtain Ash Lip Kit prior to brick installation.

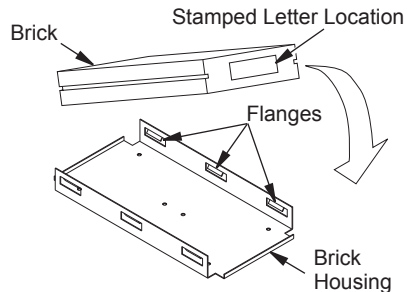

Figure 19 - Installing Brick

BRICK INSTALLATION

Continued

HERRINGBONE BRICK MATRIX

BRICK MATRIX														
BRICK MATRIX	Full	AAA	AAB	AAC	AAD	AAE	AAF	AAK	AW	AX	G	H	PA	PAA
Box #1 Hearth	20	-	-	-	-	-	-	2	-	-	2	2	-	-
Box #2 Rear - Lower	11	-	-	-	-	3	-	-	-	-	-	-	2	-
Box #3 Rear - Upper	24	-	-	-	3	-	-	-	-	-	-	-	-	-
Box #4 Left	21	-	1	-	1	1	-	-	9	1	-	-	-	-
Box #5 Right	21	1	-	1	1	1	1	-	9	1	-	-	-	1
TOTAL	97	1	1	1	5	5	1	2	18	2	2	2	2	1

BRICK MATRIX (Continued)													
BRICK MATRIX	PAB	PAC	PAD	PAE	PAF	PAG	PAH	PAI	PAJ	PAK	PAL	PAM	
Box #1 Hearth	-	-	-	-	-	-	-	-	-	-	-	-	
Box #2 Rear - Lower	-	-	-	-	-	-	-	-	-	-	-	-	
Box #3 Rear - Upper	-	-	-	-	-	-	-	-	-	-	-	-	
Box #4 Left	-	-	-	3	1	1	1	1	1	1	1	1	
Box #5 Right	1	1	1	-	-	-	-	-	-	-	-	-	
TOTAL	1	1	1	3	1	1	1	1	1	1	1	1	

BRICK MATRIX (Continued)												
BRICK MATRIX	PAN	PAO	PAP	PB	PC	PD	PE	PF	PG	PH	PJ	PK
Box #1 Hearth	-	-	-	-	-	-	-	-	-	-	-	-
Box #2 Rear - Lower	-	-	-	8	2	2	2	-	-	1	1	1
Box #3 Rear - Upper	-	-	-	1	-	-	2	2	3	1	-	1
Box #4 Left	1	1	1	-	-	-	1	1	-	-	-	-
Box #5 Right	-	-	-	-	-	-	1	1	-	-	-	-
TOTAL	1	1	1	9	2	2	6	6	3	2	1	2

BRICK MATRIX (Continued)																		
BRICK MATRIX	PL	PM	PN	PO	PP	PQ	PR	PS	PT	PU	PV	PW	PX	PY	PZ	W	Y	TOTAL
Box #1 Hearth	-	-	-	-	-	-	-	-	-	-	-	-	-	-	-	2	2	30
Box #2 Rear - Lower	-	-	-	-	-	-	-	-	-	1	-	-	-	-	-	-	-	36
Box #3 Rear - Upper	-	1	8	2	2	1	3	-	6	-	-	-	-	-	-	-	-	60
Box #4 Left	1	-	-	1	1	-	-	-	11	-	-	-	-	-	-	-	-	64
Box #5 Right	-	-	1	1	1	-	-	3	11	1	-	1	1	1	1	-	-	64
TOTAL	1	1	9	4	4	1	3	3	28	1	1	1	1	1	2	2	254	

BRICK INSTALLATION

Continued

INSTALLING Z-SHAPED GRATE RETAINER BRACKET

Before grouting the bricks, locate the z-shaped grate retainer brackets on top of the hearth bricks as shown in Figure 21. Position the retainer brackets at 8 3/4" apart from center to center of notch.

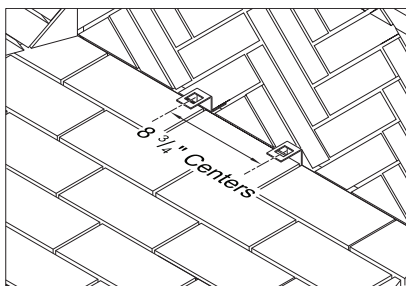

Figure 21 - Installing Grate Retainer Bracket

GROUTING INSTRUCTIONS

Material provided:

2 - 10 lb. bags of cement

2 - 10 lb. bags of sand

Material required:

1 - Piping bag

1 - Joints striker

1 - Heavy duty mixing bucket

1 - Trowel

1. Moisten brick surface with damp sponge or spray bottle just prior to application. When bricks are wet, any excess grout mixture on bricks will easily wipe off.
2. In a heavy duty mixing bucket, pour seven (7) cups of water. Add 5 lbs. (half of a bag) of sand and 5 lbs (half of a bag) of cement. Mix together well using a power drill with mixing wand attachment.
3. The overall length of piping bag should be about 16". If the bag is longer than 16", cut it down to size by removing end with larger opening. This will make the bag easier to handle.

4. Put 2 to 3 cups of grout mixture into piping bag making sure the smaller opening is downward and over a moist towel to avoid spilling. Place a wet towel over the bucket making sure it is directly on the surface of grout mixture. This will keep the mixture moist and it will not dry out before use.
5. Begin grouting by first doing a "Filler Pass". This is done by filling the joint about 3/4 full with grout mixture. It is important to work with only 6 bricks at a time so grout doesn't have time to set up before striking.
6. Complete a "Finishing Pass" around 6 bricks you just put filler pass around. This is done by slowly filling in remainder of the joint with a thick amount of grout mixture. Mixture should be a little higher than the brick surface.
7. Using a trowel, remove excess grout mixture by moving trowel in the direction of the joint. Grout mixture in the joint should now be flush with brick surface.
8. Using a joint striker, force grout mixture into joint and sweep back and forth until grout is smooth and round. If grout becomes too shallow, add more grout mixture with piping bag and strike again.
9. Continue procedure around each group of 6 bricks until an entire panel is finished.
10. Using trowel, scrape in direction of joints to remove any grout that may have collected around bricks during striking. If desired, take a moist sponge and lightly sweep over bricks to remove any grout that may have gotten on bricks. **DO NOT PRESS HARD OR RUB IN A CIRCULAR MOTION.** This will press the grout into brick and turn brick a different color.

Allow 72 hours before operating fireplace.



Figure 22 - Grouting Brick

GLASS DOOR INSTALLATION

IMPORTANT: Install top and bottom rails and hardware before installing glass door panels.

DOOR AND RAIL INSTALLATION FOR MODELS BDMO48E, BDMO48G AND BDMO48C

IMPORTANT: This optional glass door kit can NOT be used with your fireplace if you have installed the optional Ash Lip Kit.

Rail installation

1. Remove screws securing top face to firebox (see Figure 23).
2. Align holes on rail to be installed at top and replace screws. **Note:** Door rails are identical until spring clips are in place.
3. Using remaining door rail as a template, place along front row of bricks at bottom making sure rail front surface is flush with fireplace bottom face surface. Mark hole centers and remove rail (see Figure 23).
4. Drill 9 - 5/32" diameter holes about 1" deep directly into bricks using a 5/32" concrete drill bit (not provided).

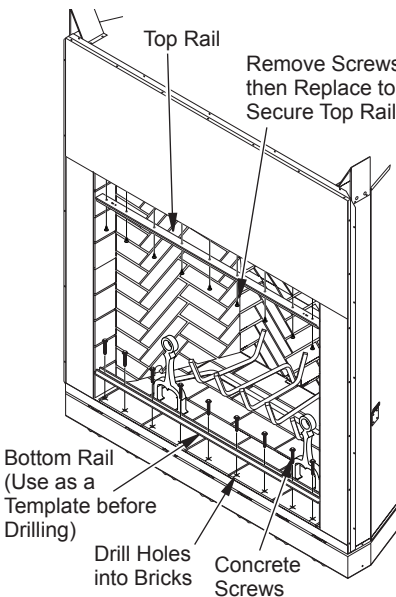

**Figure 23 - Securing Door Rails to
Fireplace**

5. Place rail back on bricks and align holes. Secure using 9 concrete screws provided with glass door kit.
6. Secure mounting clips to top and bottom rails (see Figure 24).

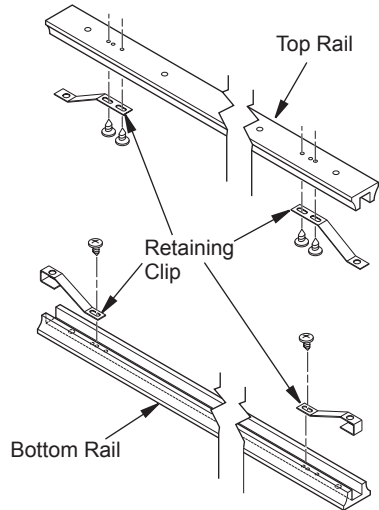

**Figure 24 - Mounting Door Retaining
Clips**

Installing Glass Doors

After spring clips have been installed some adjustments may be needed. Install the doors using the following steps:

1. With bi-fold doors completely folded, insert bottom pivot pin into bottom retaining clip located at far left and far right side of bottom rail. Swing door to vertical position making sure top pins slide into top door rail. Door is installed when top door pin snaps into spring clip (see Figure 25, page 16).
2. Repeat step 1 for remaining door.

If you find the doors do not close properly or do not appear level or straight, proceed with section on door adjustment, page 16.

GLASS DOOR INSTALLATION

Continued

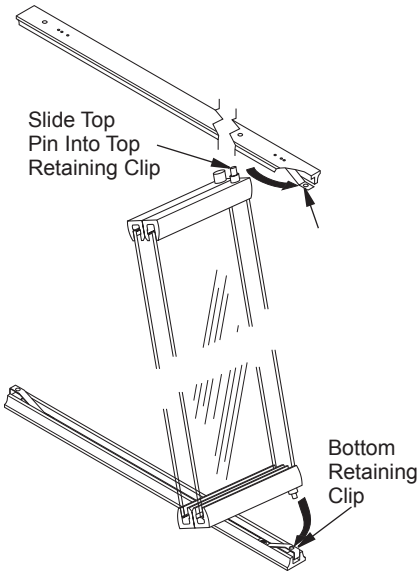

Figure 25 - Installing Doors

DOOR ADJUSTMENT

Remove doors and slightly loosen upper spring clips. Replace and fully close doors. Use 1/8" shims (any material) to level doors. Once proper setting is achieved, carefully open doors enough to access top retaining clips with a phillips screwdriver. Tighten screws. See Figure 26.

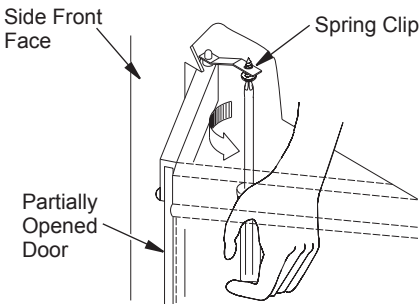

Figure 26 - Adjusting Bi-Fold Doors

OPERATION AND MAINTENANCE GUIDELINES

GLASS DOORS

Glass doors are optional with fireplace. When fireplace is in operation, doors must be fully opened or fully closed position only or a fire hazard may be created (see Figure 27).

A fireplace equipped with glass doors operates much differently than a fireplace with an open front. A fireplace with glass doors has a limited amount of air for combustion.

Excessive heat within the fireplace can result if too large a fire is built or if combustion air gate is not completely open. The following tips should be followed to assure that both the fireplace and glass door retain their beauty and function properly. Both the flue damper and glass doors must be fully opened before starting fire. This will provide sufficient combustion air and maintain safe temperatures in firebox.

IMPORTANT: The glass must be allowed to warm slowly and evenly. Such materials as pitch/wax laden logs, very dry mill end lumber and large amounts of paper or cardboard boxes can create an excessively hot fire and should not be burned in this fireplace. Always keep the fire well back from the doors and never allow flames to contact the glass.

⚠ WARNING: Fireplaces equipped with glass doors should be operated only with doors fully opened or doors fully closed. Doors, if left partly open, may draw gas and flame out of the fireplace opening creating risks of both fire and smoke.

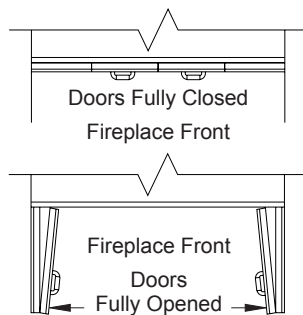

Figure 27 - Bi-Fold Glass Doors

OPERATION AND MAINTENANCE GUIDELINES

Continued

Cleaning Glass

Clean glass with any commercial glass cleaner or soap and water. Do not use any abrasive material to clean glass. Do not clean glass with any cool water if glass is still hot from the fire and smoke.

A gas line or gas log lighter may be installed for the purpose of installing a vented or vent-free decorative gas appliance incorporating an automatic shutoff device and complying with the *Standard for Decorative Gas Appliances for Installation in Vented Fireplaces, ANSI Z21.60* or *American Gas Association draft requirements for Gas Fired Log Lighters for Wood Burning Fireplaces, Draft NO. 4* dated August, 1993.

If you wish to install an unvented (vent-free) gas log set, only unvented gas log sets which have been found to comply with the standard for unvented room heaters, ANSI Z21.11.2 are to be installed in this fireplace.

DAMPER HANDLE OPERATION

The damper handle opens and closes the damper blade and is located in the upper rear side of fireplace just above rear bricks. Rotate handle counterclockwise slightly to disengage from retaining bracket. Swing slowly toward opening of fireplace. Engage handle to secondary bracket located at front of fireplace inner wall (see Figure 28).

CAUTION: When operating damper door, please be aware of sharp edges and corners. Open and close damper door slowly to avoid injury.

WARNING: Risk of fire! Replace grate with DESA model 109496-01 grate only. This grate has been designed to keep the operation of your fireplace safe and efficient.

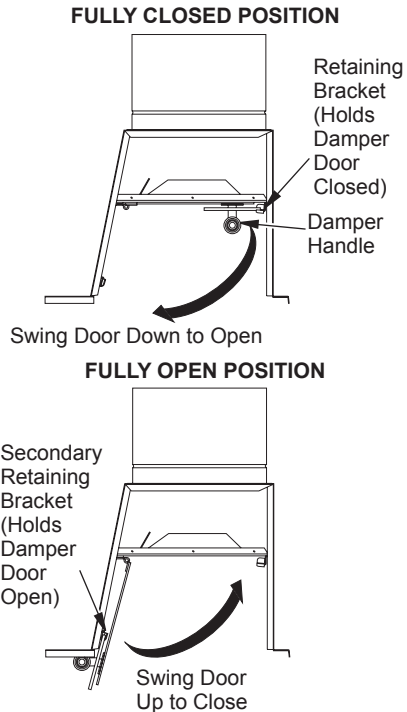
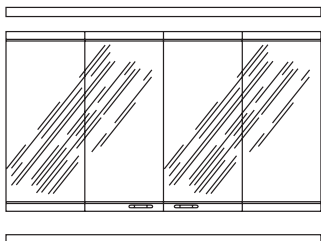

Figure 28 - Operating Damper Handle

REPLACEMENT AND ACCESSORY PARTS



BI-FOLD GLASS MASONRY DOOR

BDMO48E - 48" Ebony
BDMO48G - 48" Pewter
BDMO48C - 48" Oiled Bronze

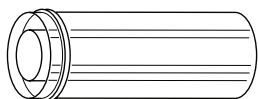

DOUBLE WALL PIPE - 12-12DM,
18-12DM, 24-12DM, 36-12DM, 48-12DM,
12-12HT, 18-12HT, 24-12HT, 36-12HT and
48-12HT

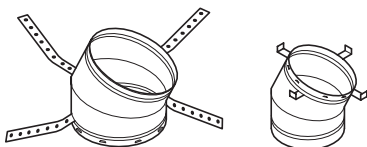

30° OFFSET AND RETURN
30E-12DM and 30E-12HT

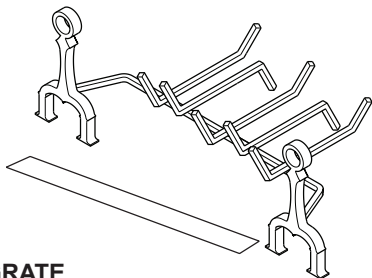

GRATE

109496-01 - Model GM50

EMBER PROTECTOR - EP36

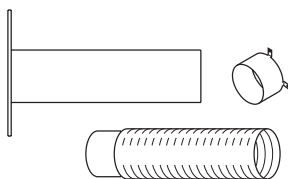

OPTIONAL OUTSIDE AIR KIT FOR
FLOOR INSTALLATION - AK4F

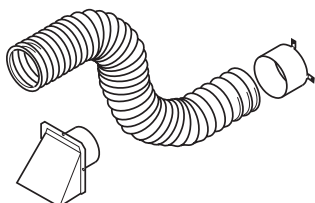

OPTIONAL OUTSIDE AIR KIT FOR
SIDEWALL INSTALLATION - AK4



STORM COLLAR - SC2-1

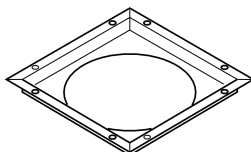

FIRESTOP SPACER - FS-10

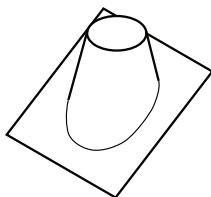

ROOF FLASHING

V6F-10DM - 0 to 6/12 Pitch

V12F-10DM - 6/12 to 12/12 Pitch

REPLACEMENT AND ACCESSORY PARTS

Continued

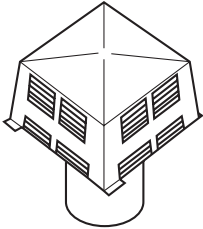

**SQUARE CHASE-TOP
TERMINATION - STL-12D**

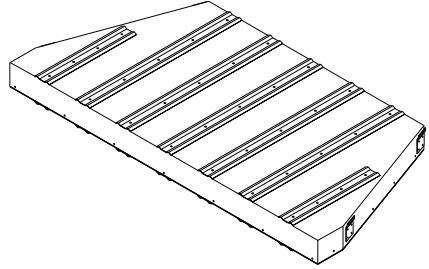

**OPTIONAL HEARTH SPACER
HS48**

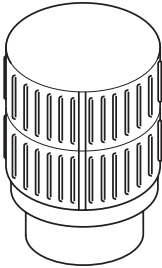

**ROUND TOP TERMINATIONS
RLT-12D AND RLT-12HT**

TECHNICAL SERVICE

You may have further questions about installation, operation, or troubleshooting. If so, contact DESA's Technical Service Department at 1-866-672-6040. When calling please have your model and serial numbers of your heater ready.

You can also visit DESA's technical services web site at www.desatech.com.

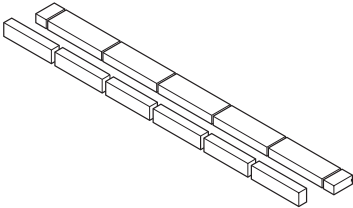

**OPTIONAL ASH LIP KIT (BRICKS)
AL48**

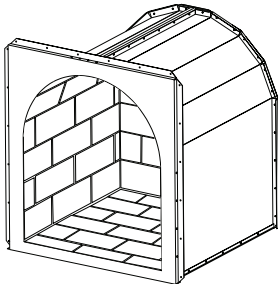

24" ROUND WOODNOOK



2701 Industrial Drive
P.O. Box 90004
Bowling Green, KY 42102-9004
www.desatech.com



118116 01

NOT A UPC

118116-01
Rev. C
12/06