



- S36** 36" textured white refractory brick
- S36H** 36" textured white herringbone refractory brick
- S36R** 36" textured red refractory brick
- S36RH** 36" textured red herringbone refractory brick
- VS36(1)** 36" smooth white refractory brick
- VS36H(1)** 36" smooth white herringbone refractory brick

RESIDENTIAL AND OUTDOOR WOODBURNING FIREPLACE INSTALLATION INSTRUCTIONS

SAVE THIS BOOK

This book is valuable. In addition to instructing you on how to install and maintain your appliance, it also contains information that will enable you to obtain replacement parts or accessory items when needed. Keep it with your other important papers.

This fireplace is approved for use as a wood burning fireplace or for use with a vented gas log approved to ANS Z21.60, Z21.84 or RGA 2-72 standards or for use with a vent-free gas log heater approved to ANS Z21.11.2 standard. A DESA hood must be installed when using a vent-free gas log heater (see Accessories, p. 12).

▲ **WARNING:** Always leave glass doors fully opened or fully closed when operating this fireplace.

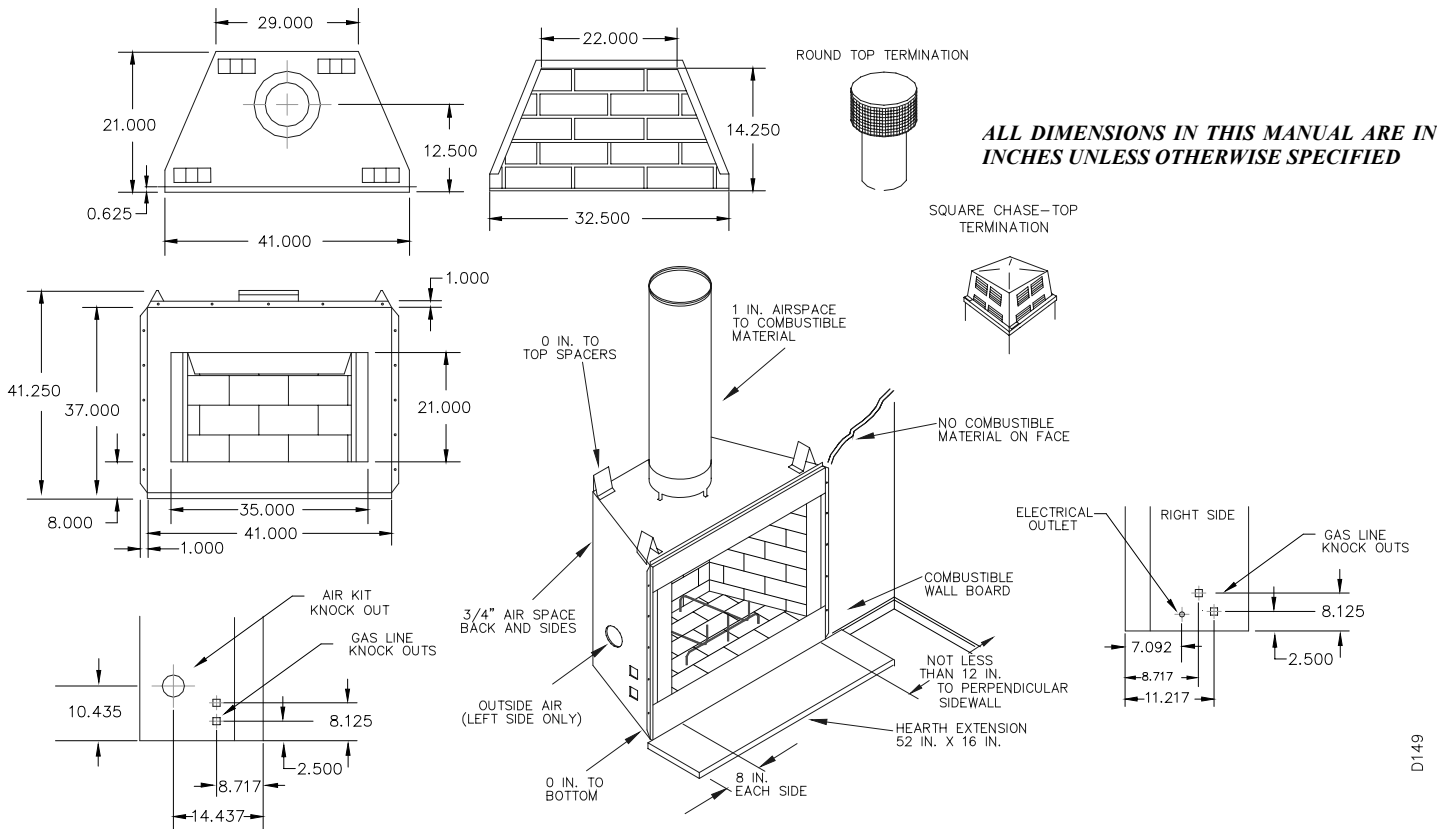

D149

DESA INTERNATIONAL
 2701 INDUSTRIAL DRIVE
 P.O. BOX 90024
 BOWLING GREEN, KY 42101-9004
www.desatech.com



OMNI-Test Laboratories, Inc.

P/N 111026-01
REV A
11/02

CONTENTS

1.	INTRODUCTION	-----	PG. 2
2.	SELECTING LOCATION	-----	PG. 2
3.	MINIMUM CLEARANCES	-----	PG. 2
4.	FRAMING AND INSTALLING	-----	PG. 3
5.	HEARTH EXTENTION	-----	PG. 3
6.	OUTSIDE AIR KIT INSTALLATION	-----	PG. 3
7.	CHIMNEY PIPE AND OFFSET INSTALLATION	-----	PG. 4-5
8.	FIRESTOP SPACERS	-----	PG. 5
9.	FLASHING AND TERMINATION	-----	PG. 6-7
10.	FINISHING YOUR FIREPLACE	-----	PG. 7
11.	MANTELS	-----	PG. 8
12.	GLASS DOORS	-----	PG. 8
13.	GAS LINE INSTALLATIONS	-----	PG. 9
14.	DAMPER OPERATION	-----	PG. 10
15.	TECHNICAL SERVICE	-----	PG. 10
16.	ILLUSTRATED PARTS	-----	PG.11-11a
17.	REPLACEMENT AND TECHNICAL PARTS	-----	PG.12

FOR YOUR SAFETY

- Do not store or use gasoline or any other flammable vapors or liquids in the vicinity of this or any other appliance.
- Due to high temperatures, the appliance should be located out of traffic and away from furniture and draperies.
- Do not place clothing or other flammable materials on or near the appliance.
- NEVER leave children unattended when a fire is burning in the fireplace.

▲ WARNING: Improper installation, adjustment, alteration, service or maintenance can cause injury, property damage, or loss of life. Refer to this manual for assistance or additional information. Consult a qualified installer or local distributor.

CHECK LOCAL CODES BEFORE INSTALLING THIS FIREPLACE.

INTRODUCTION

BEFORE BEGINNING THE INSTALLATION OF THE FIREPLACE, READ THESE INSTRUCTIONS THROUGH, COMPLETELY.

- ◆ This DESA fireplace and its components are safe when installed according to this installation manual. Unless you use DESA components, which has been designed and tested for the fireplace system, you may cause a fire hazard.
- ◆ The DESA warranty will be voided by and DESA disclaims any responsibility for the following actions:
 - a) Modification of the fireplace, components, doors, air inlet system and damper control.
 - b) Use of any component part not manufactured or approved by DESA in combination with a DESA fireplace system.

PROPER INSTALLATION is the most important step in ensuring safe and continuous operation of the fireplace. Consult the local building codes as to the particular requirements concerned with the installation of all factory built fireplaces

▲ WARNING: Do not install a fireplace insert in this box unless the manufacturers instructions with the insert specifically state this fireplace has been tested for use with the insert.

USE SOLID WOOD OR PROCESSED SOLID FUEL FIRELOGS ONLY.

▲ WARNING: When processed wood fuel fire logs are used, do not poke or stir the logs while they are burning. Use only fire logs that have been evaluated for the application in fireplace and refer to fire log warnings and caution markings on packaging prior to use.

This fireplace is not intended to be used as a substitute for a furnace to heat an entire home. Use for supplemental heat only.

This wood-burning fireplace complies with **UL 127-CAN/ULS-S610-M87** standard as a **FACTORY BUILT FIREPLACE.**

FOR CANADA: The authority having jurisdiction (such as the municipal building department, fire department, etc.) should be contacted before installation to determine the need to obtain a permit.

SELECTING LOCATION

To determine the safest and most efficient location for the fireplace, you must take into consideration the following guidelines:

- 1.) The location must allow for proper clearances (see figures 1 & 2).
- 2.) Consider a location were the fireplace would not be affected by drafts, air conditioning ducts, windows or doors.
- 3.) A location that avoids the cutting of joists or roof rafters will make installation easier.
- 4.) An outside air kit is available with this fireplace. For more details refer to section on outside air kit installation on page 3.

MINIMUM CLEARANCES TO COMBUSTIBLES

- Back and side of fireplace ----- 3/4" minimum
- Note: The 3/4" clearance is not required at the nailing flanges
- Floor* ----- 0" minimum
- *See step 2 of "Installing the Fireplace" on page 3
- Perpendicular Wall to Opening of unit - 12" minimum
- Top Spacers ----- 0" minimum
- Mantel Clearances ----- see page 8 "Mantels"
- Chimney Outer Pipe Surfaces ----- 1" minimum

▲ WARNING: Do not pack required air spaces with insulation or other materials.

MINIMUM / MAXIMUM CHIMNEY HEIGHT

RESIDENTIAL INSTALLATION

The minimum height of the chimney, measured from the base of the fireplace to the flue gas outlet of the termination, is 14.5 feet for straight flue or a flue with one elbow set. The maximum distance between elbows is 6 feet. For systems with two elbow sets, the minimum height is 22 feet. The maximum height of any system is 50 feet. This measurement includes the fireplace, chimney sections and the height of the termination assembly at the level of the flue gas outlet (see page 7, figure 15).

OUTDOOR INSTALLATION

The minimum height of the chimney, measured from the base of the fireplace to the flue gas outlet of the termination, is 7.5 feet (minimum 4 feet of chimney pipe section required for outdoor installation).

FRAMING AND INSTALLING THE FIREPLACE

STEP 1: Frame the opening for the fireplace using the dimensions shown in figures 1 & 2.

STEP 2: If the fireplace is to be installed directly on carpeting, tile (other than ceramic), or any combustible material other than wood flooring, the fireplace must be installed upon a metal or wood panel extending the full width and depth of the fireplace.

STEP 3: Set the fireplace directly in front of this opening and slide the unit back until the nailing flanges touch the side framing.

STEP 4: Check the level of the fireplace and shim with sheet metal if necessary. Make sure the unit is balanced on each side.

STEP 5: Before securing fireplace to prepared framing, the ember protector (provided), must be placed between the hearth extension (not supplied), and under the bottom front edge of the fireplace to protect against glowing embers falling through. If the fireplace is to be installed on a raised platform, a Z-type ember protector (not supplied) must be fabricated to fit your required platform height. The ember protector should extend under the fireplace a minimum of 1 - 1/2". The ember protector should be made of galvanized sheet metal (28-gage minimum).

STEP 6: Using screws or nails, secure the fireplace to the framing through flanges located on the sides of the fireplace.

NOTE: For outdoor installations, the fireplace enclosure must allow for adequate drainage and fresh air ventilation. It is recommended that a sealed, corrosion resistant catch pan with provision for drainage, be installed under the fireplace within the fireplace enclosure.

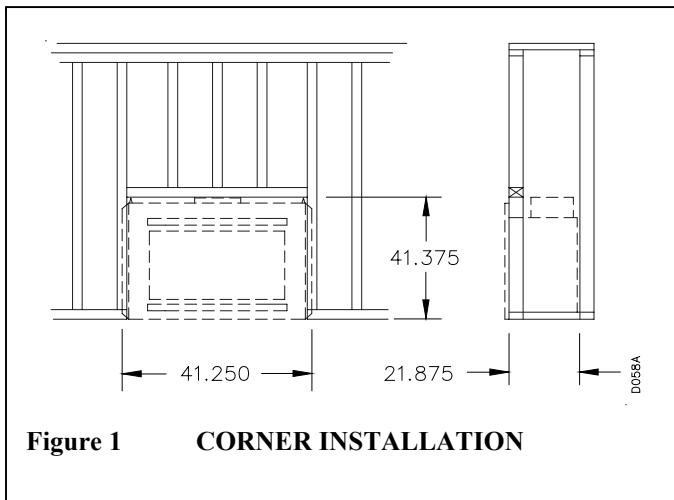

Figure 1 CORNER INSTALLATION

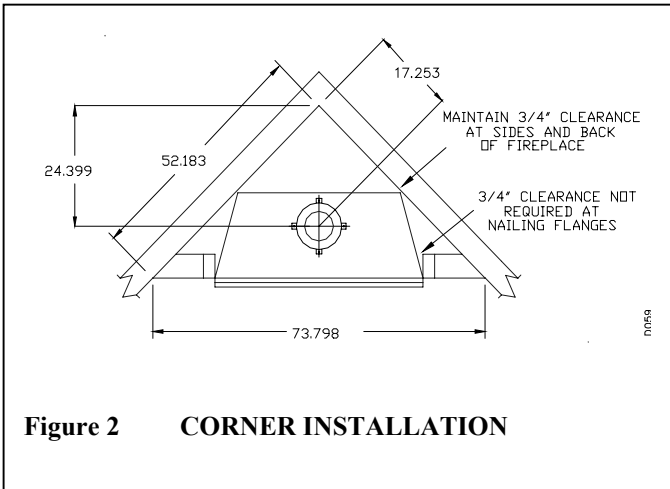

Figure 2 CORNER INSTALLATION

HEARTH EXTENSION

A hearth extension projecting a minimum of 16" in front of and a minimum of 8" beyond each side of the fireplace opening is required to protect combustible floor construction in front of the fireplace. Fabricate a hearth extension using a material which meets the following specifications: a layer of non-combustible, inorganic material having a thermal conductivity of $K = 0.84 \text{ BTU IN/FT. HR. F}$ (or less) at 1" thick. For example, if the material selected has a K factor of 0.25, such as glass fiber, the following formula would apply:

$$\frac{0.25 \times 1.0}{0.84} = 0.30 \text{ thickness required}$$

Thermal conductivity "K" of materials can be obtained from the manufacturer or supplier of the non-combustible material.

If the hearth extension is to be covered, use non-combustible material such as tile, slate, brick, concrete, metal, glass, marble, stone etc. Provide a means to prevent the hearth extension from shifting and seal gap between the fireplace frame and hearth extension with a non-combustible material (see figure 3).

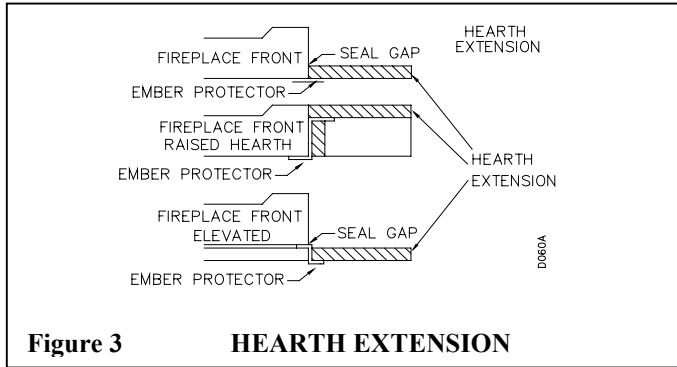

Figure 3 HEARTH EXTENSION

▲ WARNING: Hearth extension is to be installed only as illustrated.

OPTIONAL OUTSIDE AIR KIT (MODEL AK4 / AK4F)

The installation of an outside air kit should be performed during the rough framing of the fireplace due to the nature of its location. Outside combustion air is accessed through a vented crawl space (AK4F) or through a sidewall (AK4). See page 10, figure 21 for instructions on how to operate the air kit.

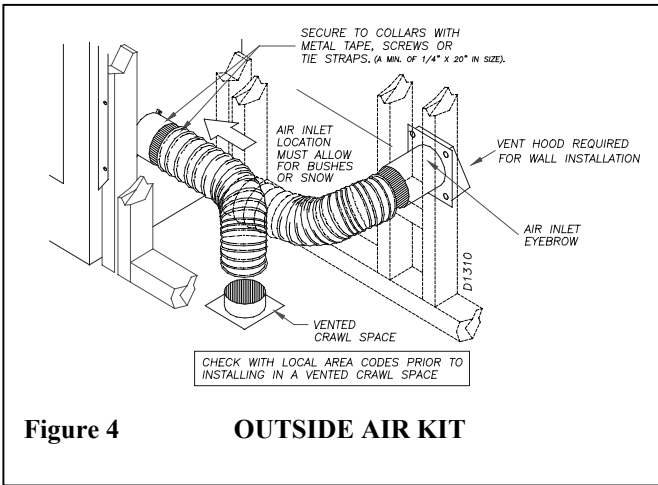

Figure 4 OUTSIDE AIR KIT

CHIMNEY PIPE

The DESA chimney system consists of 12, 18, 24, 36 and 48 inch, snap-lock double-wall pipe segments, planned for maximum adaptability to individual site requirements. Actual lengths gained after fitting overlaps must be taken into consideration (lineal gain) and are given in the lineal gain chart (see figure 5).

ASSEMBLY AND INSTALLATION OF THE DOUBLE WALL CHIMNEY SYSTEM

Each double wall chimney section consists of a galvanized outer pipe, a stainless steel inner flue pipe and a wire spacer. The pipe sections must be assembled independently as the chimney is installed.

LINEAL GAIN: THE ACTUAL MEASURABLE LENGTH OF A PART AFTER TWO OR MORE PARTS ARE CONNECTED.
12 3/8 GALVANIZED OUTER PIPE

PART NO.	DESCRIPTION	GAIN (IN.)
36"	FIREPLACE	40
12-8DM 12-8HT	PIPE SECTION	10 5/8
18-8DM 18-8HT	PIPE SECTION	16 5/8
24-8DM 24-8HT	PIPE SECTION	23 5/8
36-8DM 36-8HT	PIPE SECTION	34 5/8
48-8DM 48-8HT	PIPE SECTION	46 5/8
RT-8DM	ROUND TERMINATION	6 7/8 *
RTL-8DM	ROUND TERMINATION	7 3/4 *
RTT-8DM	ROUND TERMINATION W/ SLIP SECTION	6-7/8 TO 23-1/8 *
RTTL-8DM	ROUND TERMINATION W/ SLIP SECTION	8-1/2 TO 21-1/2 *
ET-8DM	SQUARE CHASE-TOP	12 *
ETO-8DM	SQUARE CHASE-TOP W/ MESH	12 *
ETL-8DM	SQUARE CHASE-TOP W/ SLIP SECTION	7 TO 16 *
ETLO-8DM	SQUARE CHASE-TOP W/ MESH & SLIP SECTION	12 TO 25-1/2 *

* THE LINEAL GAIN FOR THE TERMINATIONS IS MEASURED TO THE FLUE GAS OUTLET HEIGHT.

D062

Figure 5 LINEAL GAIN

For Canada, use chimney parts designated "HT"
When connecting chimney directly to the fireplace, the inner flue pipe section must be installed first with the lanced side up. The outer pipe section can then be installed over the flue pipe section with the hemmed end up. Press down on each pipe section until the lances securely engage the hem on the fireplace starter. The wire will assure the proper spacing between the inner and outer pipe sections. Continue to assemble chimney sections as outlined above, making sure that both the inner and outer pipe sections are locked together. When installing double wall "snap lock" chimney together, it is important to assure the joint between the chimney sections is locked. Check by pulling chimney upward after locking. The chimney will not come apart if properly locked. It is not necessary to add screws to keep the chimney together (exception – see page 5 figure 8).

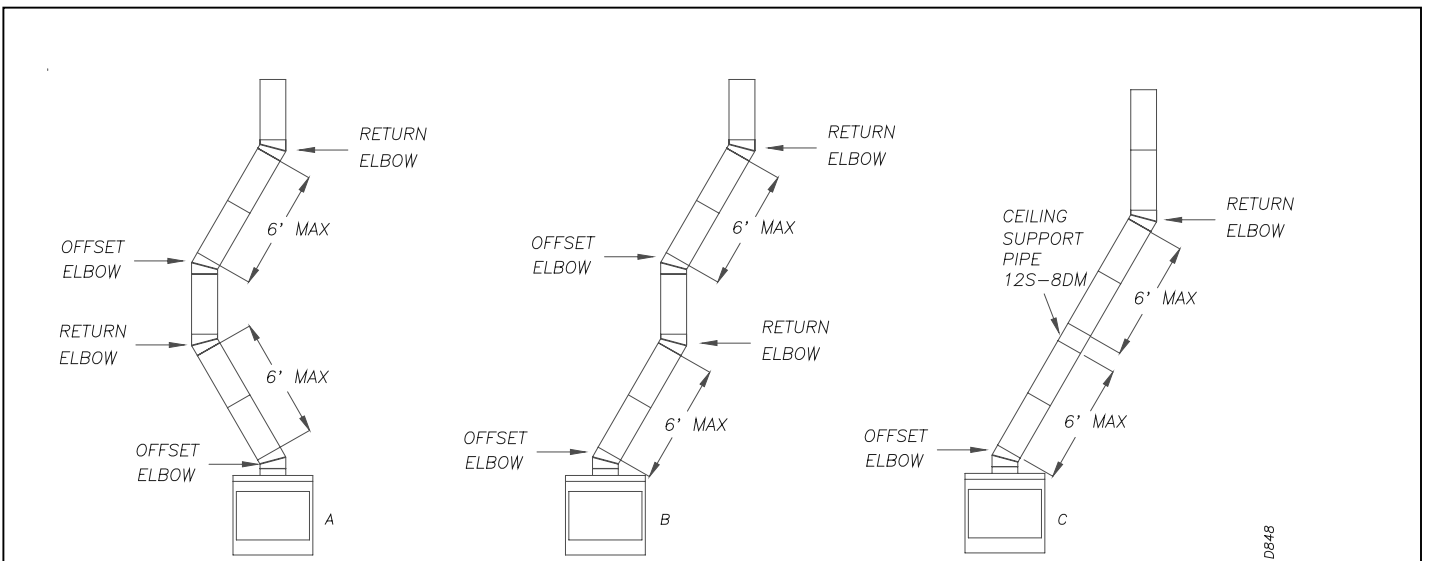

Figure 6 *TYPICAL OFFSET INSTALLATION

*For systems with two elbow sets, the minimum height is 22 feet. The maximum height for any system is 50 feet.

▲ WARNING: The opening in the collar around the chimney at the top of the fireplace must not be obstructed. Never use blown insulation to fill the chimney enclosure.

INSTRUCTIONS WHEN ELBOW OFFSET (30E-8DM) OF CHIMNEY IS NEEDED

1. To achieve desired offset, you may install combinations of 12", 18", 24", 36" and 48" length of double wall pipe (SEE SINGLE OFFSET CHART AND FIGURE 6).
2. Chimney weight above offset rests on return elbow. Straps must be securely nailed to rafters or joists (see figure 7, details a & b).
3. Maximum length of pipe between supports (return elbow or 12S-8DM) is 6' of angle run. Maximum of two (2) 6' angle run sections per chimney system (see figure 6).

OFFSET CHART (22-50 FT. SYSTEM HEIGHT)

OFFSET	RISE	CHIMNEY LENGTH							
		A	B	48"	36"	24"	18"	12"	
4 - 3/8	16 - 3/8	ELBOW SET ONLY							
9 - 3/4	25 - 1/2							1	
12 - 3/4	30 - 3/4						1	1	
15	34 - 3/4					1			
18	40						1	1	
21 - 1/4	46 - 1/4			1					
23 - 3/4	49 - 1/4					1	1		
27 - 3/4	56 - 3/4	1							
30	60 - 3/4			1			1		
33	66	1						1	
36	71	1					1		
38 - 1/4	75			2					
41 - 1/4	80 - 1/4			1			1	1	
45	86 - 3/4			2					
46 - 3/4	89 - 1/2	1					1	1	
51	97	1	1						
53 - 1/4	101			2			1		
56 - 1/4	106 - 1/4	2							
59 - 1/4	111 - 1/2	1	1				1		
61 - 3/4	115 - 1/2	2						1	
64 - 3/4	120 - 3/4	2					1		
68 - 1/4	127	1	2						
70	130	2					1	1	
74 - 1/4	137 - 1/2	1	2					1	
76 - 3/4	141 - 1/2	1	2				1		
79 - 3/4	146 - 3/4			4					

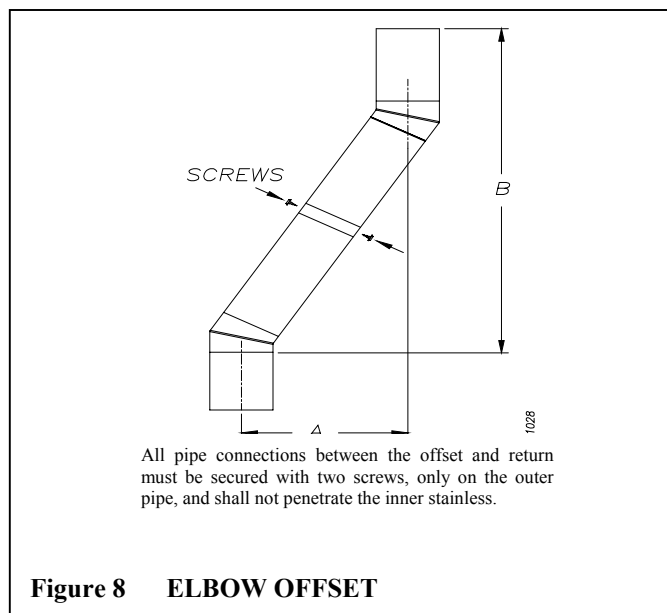

Figure 8 ELBOW OFFSET

All pipe connections between the offset and return must be secured with two screws, only on the outer pipe, and shall not penetrate the inner stainless.

When the pipe passes through a framed opening into a living space above, the firestop must be placed onto the ceiling from below as shown in figure 9.

They also provide complete separation from one floor space to another or attic space as required by most codes. When the double wall pipe passes through a framed opening into an attic space, the firestop must be placed into an attic floor as shown in figure 10.

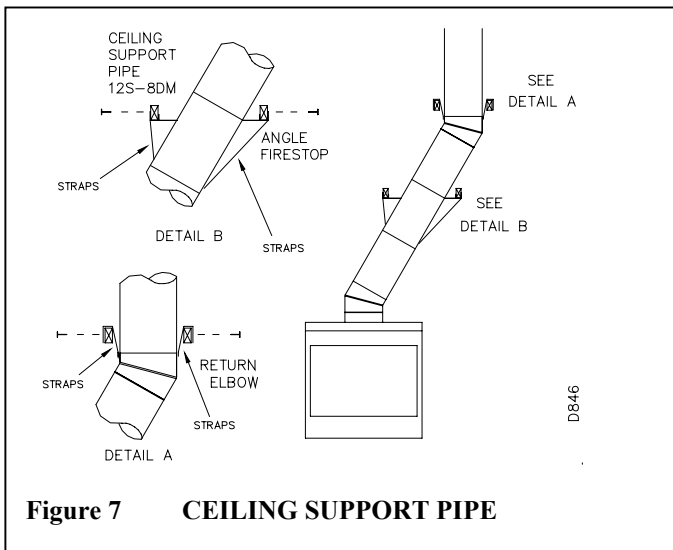

Figure 7 CEILING SUPPORT PIPE

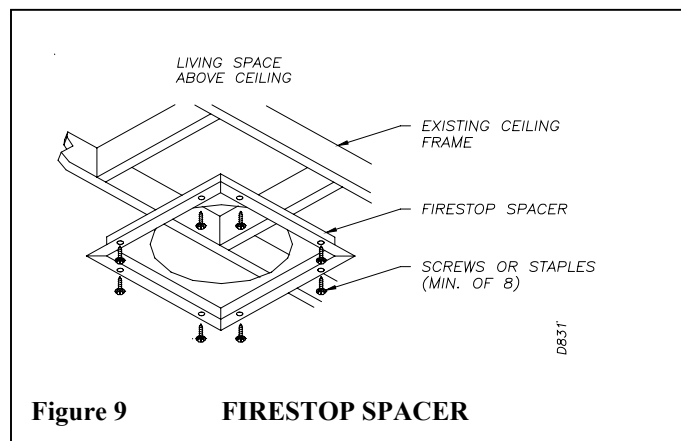

Figure 9 FIRESTOP SPACER

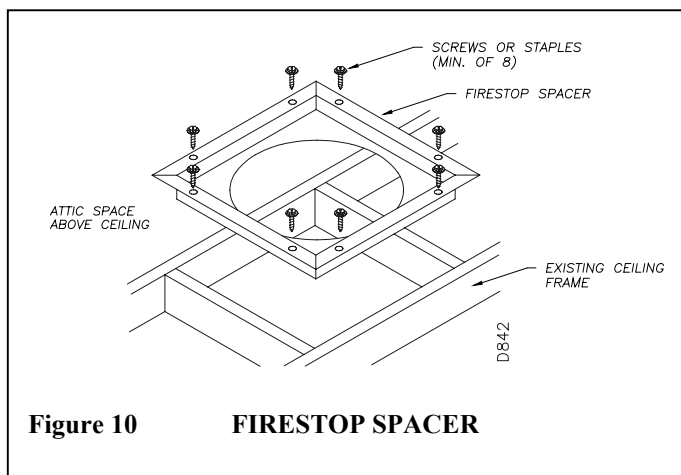

Figure 10 FIRESTOP SPACER

FIRESTOP SPACERS (V3600FS-8DM)

Firestop spacers are required at each point where the chimney penetrates a floor space. Their purpose is to establish and maintain the required clearance between the chimney and the combustible materials.

PENETRATING THE ROOF

To maintain a 1-inch clearance to the pipe on a roof with a pitch, a rectangular opening must be cut.

STEP 1: Determine the center point through which the pipe will penetrate the roof.

STEP 2: Determine the center point of the roof. Pitch is the distance the roof drops over a given span, usually 12 inches. A 6/12 pitch means that the roof drops 6 inches for each 12 inches one measure horizontally down from the roof rafters.

STEP 3: Use the roof opening chart (figure 11) to determine the correct opening length and flashing required.

STEP 4: Remove the shingles around the opening measured and cut out this section.

STEP 5: Add the next sections of the pipe until the end penetrates the roofline. Check to see that the proper clearances are maintained. Extend chimney by adding sections of double wall pipe until pipe is a minimum of 30 inches above the highest point of the roof cutout. Termination and chimney must extend a minimum of 36 inches above the highest point where it passes through roof.

INSTALLING FLASHING ON A METAL ROOF

When installing the flashing on a metal roof, it is required that putty tape be used between the flashing and the roof. The flashing must be secured to the roof using #8 x 3/4" screws and then sealed with roof coating to prevent leakage through the screw holes. A roof coating must also be applied around the perimeter of the flashing to provide a proper seal.

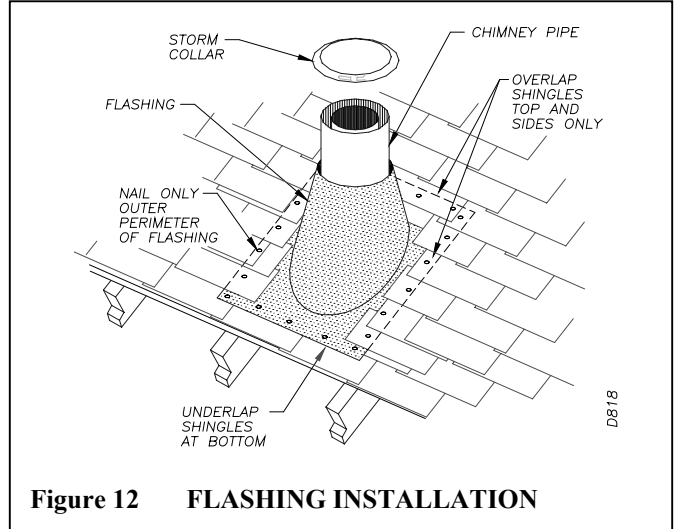

Figure 12 FLASHING INSTALLATION

STORM COLLAR INSTALLATION (SC1 or SC2)

Place storm collar over pipe and slide down until it is snug against the open edge of the flashing (see figure 13). Use SC1 for all round terminations and SC2 for all terminations with slip sections. Apply waterproof caulk around the perimeter of the collar to provide a proper seal.

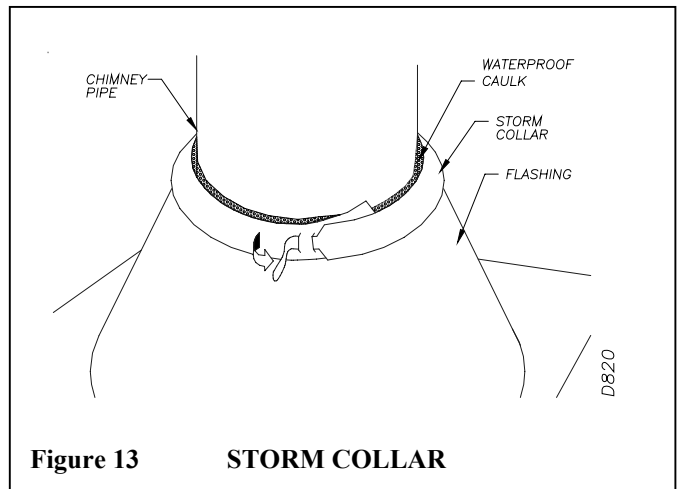

Figure 13 STORM COLLAR

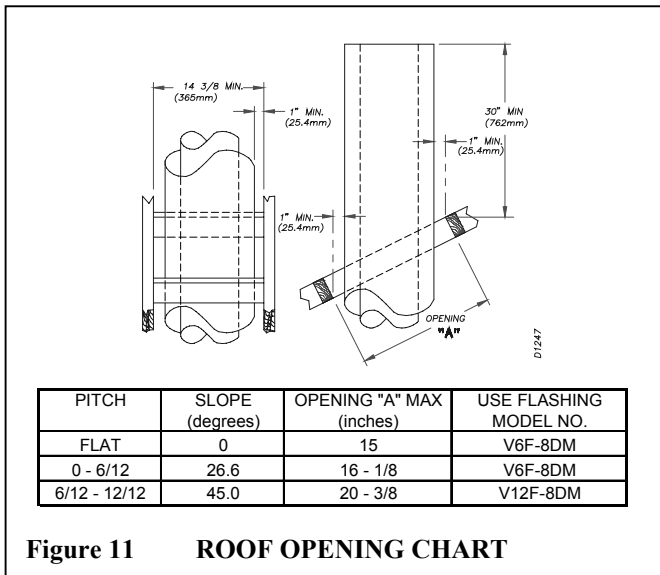

Figure 11 ROOF OPENING CHART

FLASHING INSTALLATION (V6F-8DM or V12F-8DM)

Determine the flashing to be used with the roof opening chart. Slide flashing over pipe until base is flat against roof. Replace as many shingles as needed to cover exposed area and flashing base. Secure in position by nailing through shingles (see figure 12).

DO NOT NAIL THROUGH FLASHING CONE.

TERMINATIONS / SPARK ARRESTOR

The fireplace system must be terminated with the listed round top or chase terminations. In any case, refer to the installation instructions supplied with the termination. The terminations approved for this fireplace are the RT-8DM and RTL-8DM that can be used for flashing or chase and ET-8DM, ETO-8DM, ETL-8DM and ETLO-8DM for chase style termination only. Figure 14 shows an RTL-8DM round top termination.

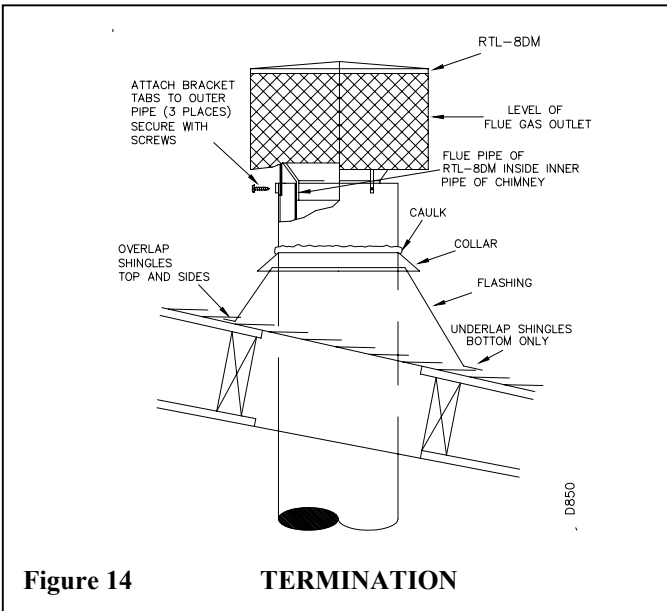

Figure 14 TERMINATION

CAUTION: Do not seal openings on the rooftop flashing. Follow the installation instructions provided with the termination being used.

Terminations with 16" slip pipe sections are available. The RTT-8DM and RTTL-8DM are approved for flashing installations. When needed, these adjustable terminations may be used in combination with the pipe assembly to achieve the correct chimney height.

NOTE: In the rare instance there is a problem with the side driven rain or wind or the chimney is not drafting properly, an ADS-8DM Anti Draft Shield can be used with round terminations.

CHASE INSTALLATIONS

Instructions for chase installations are included with the chase style termination chosen. In a multiple chase installation, be sure to provide adequate distance between terminations to prevent smoke spillage from one termination to another. We suggest that terminations be separated at least 24 inches, center to center and stacked at vertical height difference of 18 inches (see figure 15).

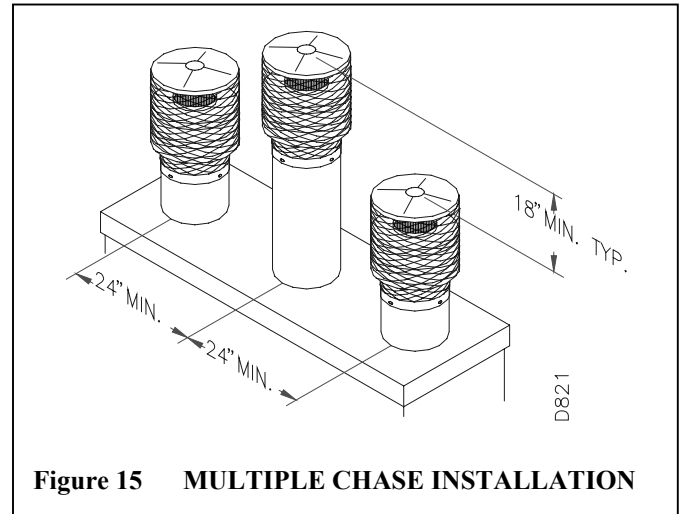

Figure 15 MULTIPLE CHASE INSTALLATION

*NOTE: If a decorative shroud is to be installed, contact the manufacturer for specifications.

10-FOOT RULE

All flue gas outlet of chimney termination must extend a minimum of 3 feet in height above the highest point where it passes through the roof and must be at least 2 feet above the highest point of the roof that is within a horizontal distance of 10 feet (see figure 16).

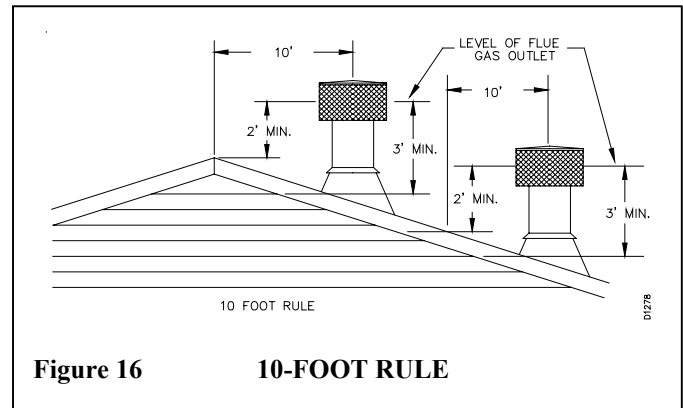

Figure 16 10-FOOT RULE

FINISHING THE FIREPLACE

Combustible materials, such as wallboard, gypsum board, sheet rock, drywall, plywood, etc. may make direct contact with sides and top periphery of the fireplace face. It is important that combustible materials do not overlap the face itself. Brick, glass, tile or other non-combustible materials may overlap the front face provided they do not obstruct essential openings like louvered slots or any other opening. When overlapping with a non-combustible facing material, use only non-combustible mortar or adhesive.

MANTELS

A mantel may be installed if desired (see figure 17), Woodwork such as wood trims, mantels, or any other combustible material projecting from the front face must not be placed within 9 inches of the fireplace.

Combustible materials above 9 inches and projecting more than 1-1/2 inches from the fireplace must not be placed less than 12 inches from the top opening of the fireplace (NFPA STD 211, Sec. 7-3.3.3).

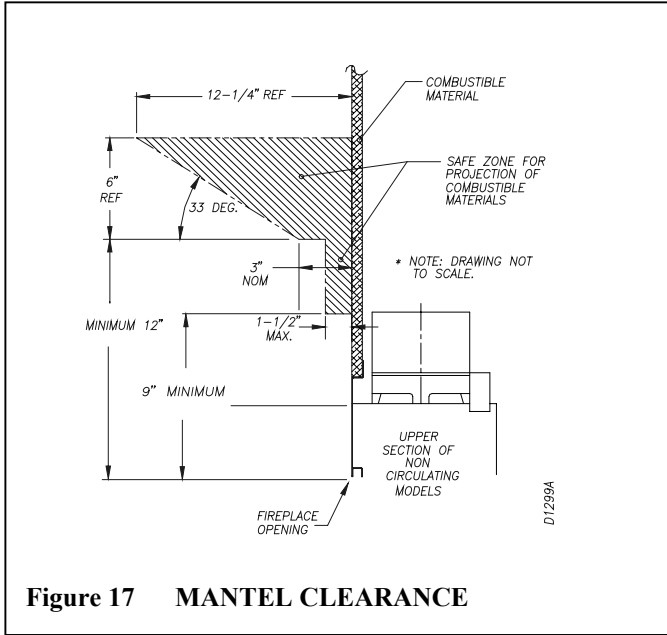

Figure 17 MANTEL CLEARANCE

Mantels or any other combustible material also may come up to the side edge of the black metal face of the fireplace just as long as the projection from the front face fall within the limit shown in figure 17a.

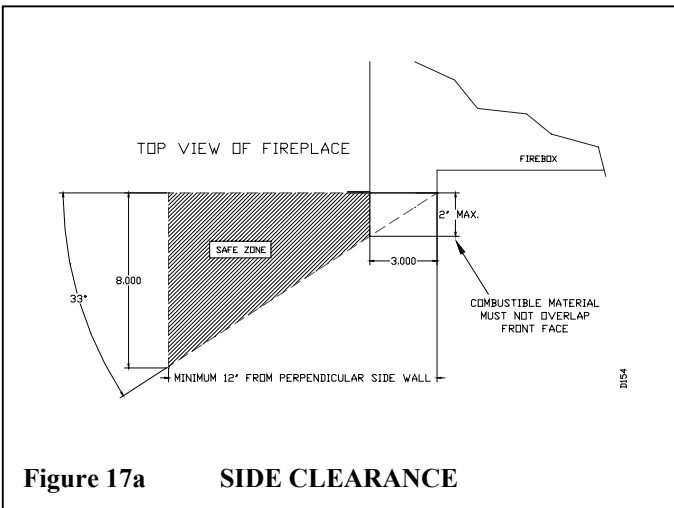

Figure 17a SIDE CLEARANCE

OPERATING GUIDELINES AND MAINTENANCE INSTRUCTIONS

GLASS DOORS

Glass doors are optional with the fireplace. When the fireplace is in operation, doors must in FULLY OPENED or FULLY CLOSED position only or a fire hazard may be created (see figure 18).

A fireplace equipped with glass doors operates much differently than a fireplace with an open front. A fireplace with glass doors has a limited amount of air for combustion. Excessive heat within the fireplace can result if too large a fire is built or if the combustion air gate is not completely open.

The following tips should be followed to assure that both the fireplace and the glass door retain their beauty and function properly. Both the flue damper and the glass doors must be fully opened before starting the fire. This will provide sufficient combustion air and maintain safe temperatures in the firebox.

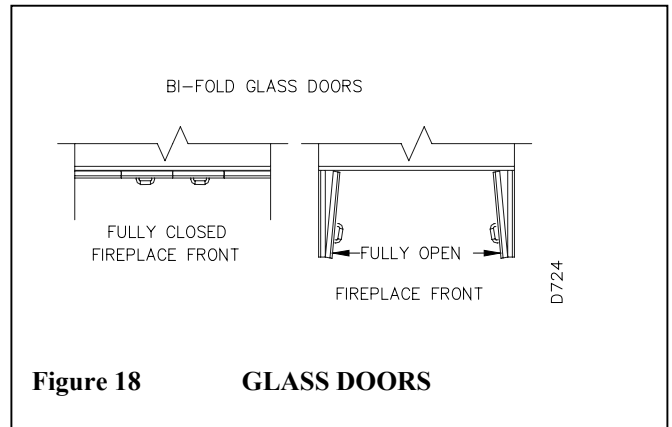

Figure 18 GLASS DOORS

IMPORTANT: The glass must be allowed to warm slowly and evenly. The tempered glass will withstand a gradual temperature rise to 550 degrees Fahrenheit, which is more than a normal fire will generate. Such materials as pitch/wax laden logs, very dry mill end lumber, and large amounts of paper or cardboard boxes can create an excessively hot fire and should not be burned in this fireplace. Always keep the fire well back from the doors and never allow flames to contact the glass.

▲ WARNING: Fireplaces equipped with glass doors should be operated only with doors fully opened or doors fully closed. Doors, if left partly open, may draw gas and flame out of the fireplace opening creating risks of both fire and smoke.

CLEANING THE GLASS

Clean the glass with any commercial glass cleaner or soap and water. Do not use any abrasive material to clean the glass. Do not clean the glass with any cool water if the glass is still hot from the fire and smoke.

A gas line or gas log lighter may be installed for the purpose of installing a vented or vent-free decorative gas appliance incorporating an automatic shutoff device and complying with the Standard for Decorative Gas Appliances for Installation in Vented Fireplaces, ANSI Z21.60 or American Gas Association draft requirements for Gas-Fired Log Lighters for Wood Burning Fireplaces, Draft No. 4 dated August, 1993.

IF YOU WISH TO INSTALL AN UNVENTED (VENT-FREE) GAS LOG SET, ONLY UNVENTED GAS LOG SETS, WHICH HAVE BEEN FOUND TO COMPLY WITH THE STANDARD FOR UNVENTED ROOM HEATERS, ANSI Z21.11.2, ARE TO BE INSTALLED IN THIS FIREPLACE.

OPTIONAL GAS LINE INSTALLATION

Gas line hook up should be done by your supplier or a qualified service person.

NOTE: Before you proceed, make sure your gas supply is turned off.

Use only a 1/2 inch black iron pipe and appropriate fittings. STEP 1: To install, remove the knockout indentation on the refractory, (or firebrick), wall located above the refractory hearth floor. The knockout indentation must be firmly tapped with any solid object until it is released. Remove fragmented portions of refractory (see figure 19).

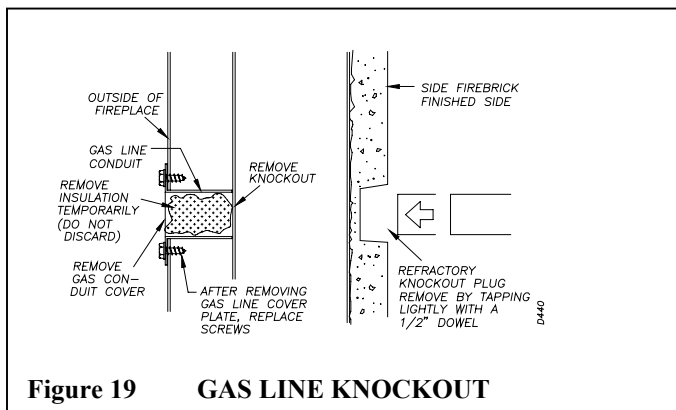

Figure 19 GAS LINE KNOCKOUT

STEP 2: Remove gas line cover plate located on either side of fireplace and pull out insulation from gas line conduit sleeve. Save insulation for reuse.

STEP 3: Run a 1/2 inch black iron gas line into the fireplace through the rear at gas line conduit sleeve (if using a raised platform, add height). Provide sufficient gas line into fireplace chamber for fitting connection (see figure 20).

NOTE: Secure incoming gas line to wood framing to provide rigidity for threaded end.

STEP 4: Repack insulation around gas line and into sleeve opening. Seal any gaps between gas line and refractory knockout hole with refractory cement or commercial furnace cement. Install the gas appliance or cap-off gas line if desired.

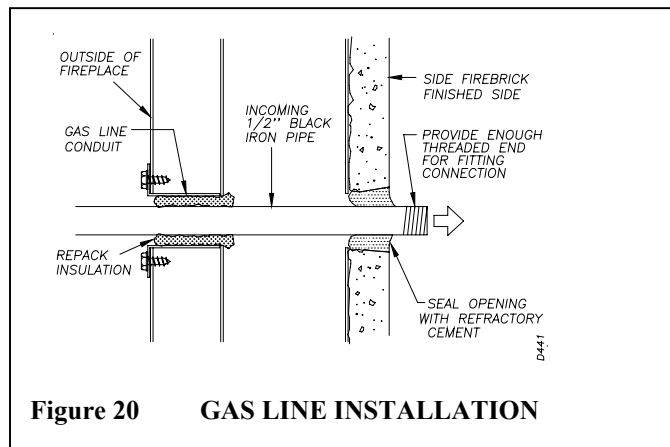

Figure 20 GAS LINE INSTALLATION

CAUTION: All gas piping and connections must be tested for leaks after the installation is completed. After ensuring that the gas valve is on, apply soap and water solution to all connections and joints. Bubbles forming show a leak. Correct all leaks at once. **DO NOT USE AN OPEN FLAME FOR LEAK TESTING AND DO NOT OPERATE ANY APPLIANCE IF A LEAK IS DETECTED. LEAK TESTING SHOULD BE DONE BY A QUALIFIED SERVICE PERSON.**

NOTE: A DESA hood must be installed when using an unvented gas log set (see accessories on page 12).

▲ WARNING: Do not operate an unvented gas log set in this fireplace with the chimney removed.

If you install a decorative gas appliance (vented gas log), the decorative gas appliance must comply with the **Standard for Decorative Gas Appliance for Installation in Solid Fuel burning Fireplaces, ANS Z21.60, Z21.84 or RGA 2-72**, and shall also be installed in accordance with the **National Fuel Gas Code, ANS Z223.1-NFPA 54** latest edition.

▲ WARNING: To avoid the risk of damaging the fireplace materials and increasing the risk of spreading a fire, do not use the fireplace to cook or warm food.

▲ WARNING: If the fireplace has been used for wood burning, the firebox and chimney must be cleaned of soot, creosote and ashes by a qualified chimney cleaner. Creosote will ignite if highly heated.

▲ WARNING: When using a decorative vented gas log, the damper must be removed or permanently locked in the fully open position and the glass doors must be in the fully open position.

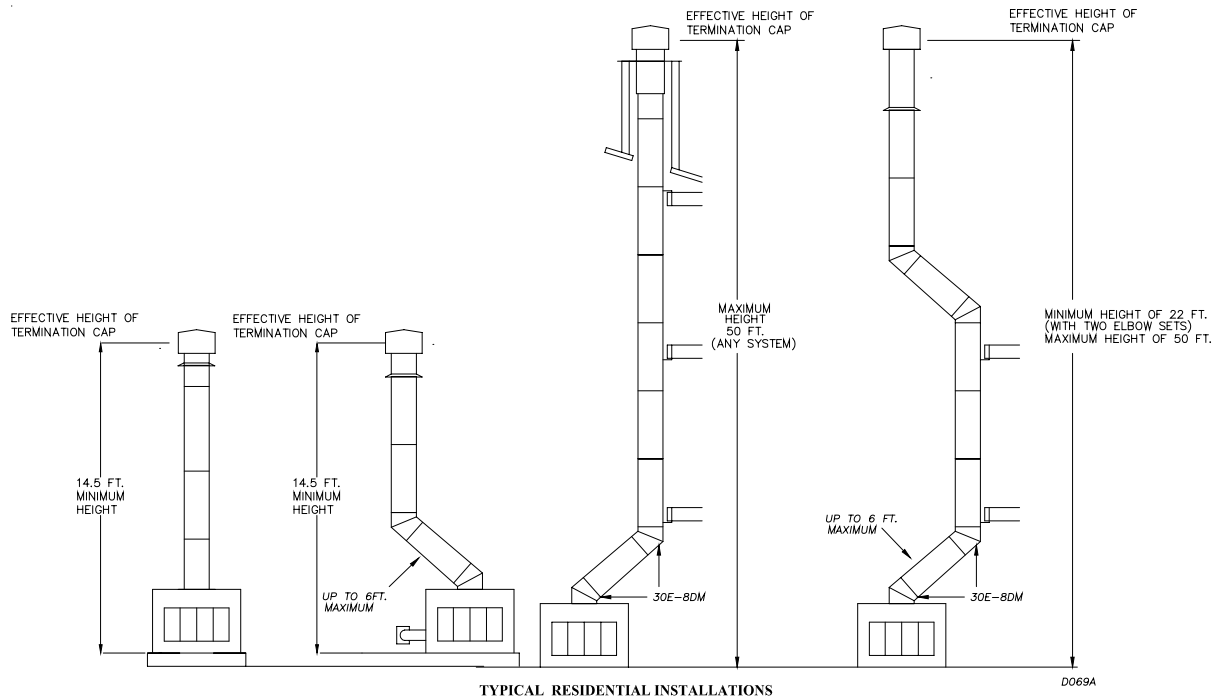

OUTSIDE AIR AND DAMPER HANDLE OPERATION

The damper handle, which opens and closes the damper blade, is located in the upper front face of the fireplace. Pushing the handle in to the left of the keyway slot will free the damper blade to automatically open. Pushing the handle in to the right will lock the damper blade closed (see figure 21).

The outside air kit handle is located at the left hand side of the fireplace (see figure 21). Pulling the handle out will free the outside air door to open. Pushing the handle in will lock the door close.

▲ WARNING: Risk of fire! Replace grate with DESA model 111028-01 grate only. This grate has been designed to keep the operation of your fireplace safe and efficient.

FOR FURTHER OPERATING GUIDELINES, INSTRUCTIONS AND WARRANTY INFORMATION, PLEASE REFER TO YOUR HOMEOWNERS GUIDE OR CONTACT YOUR AUTHORIZED DEALER.

TECHNICAL SERVICE

You may have questions about installation, operations, or troubleshooting. If so, contact the Technical Service Department at 1-866-672-6040. When calling, have the model number of the fireplace ready.

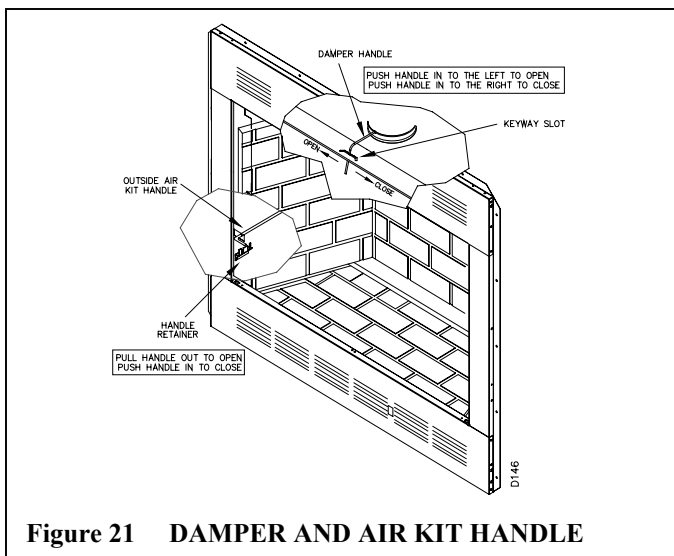

ILLUSTRATED PARTS

ITEM #	DESCRIPTION	QTY	S36	S36H	S36R	S36RH	VS36(1)	VS36H(1)
1	HOMEOWNERS GUIDE	1	106625-01	106625-01	106625-01	106625-01	106625-01	106625-01
2	INSULATION PAN	1	106638-01	106638-01	106638-01	106638-01	106638-01	106638-01
3	FIREPLACE TOP	1	106639-01	106639-01	106639-01	106639-01	106639-01	106639-01
4	FIREPLACE SURROUND	1	106641-01	106641-01	106641-01	106641-01	106641-01	106641-01
5	AIR ROD RETAINER	1	106642-01	106642-01	106642-01	106642-01	106642-01	106642-01
6	DAMPER ROD RETAINER	1	106643-01	106643-01	106643-01	106643-01	106643-01	106643-01
7	FIREBOX BOTTOM	1	106655-01	106655-01	106655-01	106655-01	106655-01	106655-01
8	FIREBOX SURROUND	1	106656-01	106656-01	106656-01	106656-01	106656-01	106656-01
9	AIR SEPARATOR	1	106657-01	106657-01	106657-01	106657-01	106657-01	106657-01
10	LEFT REFRACTORY	1	106658-03	108164-03	106658-02	108164-02	106658-01	108164-01
11	RIGHT REFRACTORY	1	106659-03	108165-03	106659-02	108165-02	106659-01	108165-01
12	REAR REFRACTORY	1	106660-03	108166-03	106660-02	108166-02	106660-01	108166-01
13	BOTTOM REAR REFRACTORY	1	110899-01	110899-01	110899-02	110899-02	110899-01	110899-01
14	BOTTOM FRONT REFRACTORY	1	110900-01	110900-01	110900-02	110900-02	110900-01	110900-01
15	FIREBOX SUPPORT LEG	4	106683-01	106683-01	106683-01	106683-01	106683-01	106683-01
16	DAMPER CAN COLLAR	1	106687-01	106687-01	106687-01	106687-01	106687-01	106687-01
17	SCREEN ROD	2	106691-01	106691-01	106691-01	106691-01	106691-01	106691-01
18	FIREBOX TOP ASSEMBLY	1	106694-01	106694-01	106694-01	106694-01	106694-01	106694-01
19	AIR KIT DOOR ASSEMBLY	1	106703-01	106703-01	106703-01	106703-01	106703-01	106703-01
20	FACE WELDMENT	1	110901-01	110901-01	110901-01	110901-01	110901-01	110901-01
21	AIR DEFLECTOR	1	110892-01	110892-01	110892-01	110892-01	110892-01	110892-01
22	FIREPLACE TOP INSULATION	1	107768-01	107768-01	107768-01	107768-01	107768-01	107768-01
23	PANEL ACCESS	1	107775-01	107775-01	107775-01	107775-01	107775-01	107775-01
24	OWNERS MANUAL	1	111026-01	111026-01	111026-01	111026-01	111026-01	111026-01
25	RIGHT REFRACTORY BRACKET	1	107854-01	107854-01	107854-01	107854-01	107854-01	107854-01
26	LEFT REFRACTORY BRACKET	1	107854-02	107854-02	107854-02	107854-02	107854-02	107854-02
27	GRATE	1	111028-01	111028-01	111028-01	111028-01	111028-01	111028-01
28	PUSH-ON NUT	2	11418	11418	11418	11418	11418	11418
29	STAINLESS SCREEN 22 x 21	2	110890-01	110890-01	110890-01	110890-01	110890-01	110890-01
30	COLLAR INSULATION	1	16405	16405	16405	16405	16405	16405
31	COLLAR, CHIMNEY STARTER	1	20023	20023	20023	20023	20023	20023
32	REFRACTORY RETAINER	2	20027	20027	20027	20027	20027	20027
33	GRATE RETAINER	2	106539-02	106539-02	106539-02	106539-02	106539-02	106539-02
34	DOOR STOP	1	111073-01	111073-01	111073-01	111073-01	111073-01	111073-01
35	PIVOT CLIP	2	111204-01	111204-01	111204-01	111204-01	111204-01	111204-01
36	SPRING CLIP	2	20090	20090	20090	20090	20090	20090
37	TOP SPACER	4	20280	20280	20280	20280	20280	20280
38	CONDUIT PLATE COVER	4	21171	21171	21171	21171	21171	21171
39	GAS CONDUIT	2	21379	21379	21379	21379	21379	21379
40	GAS CONDUIT	2	21380	21380	21380	21380	21380	21380

ILLUSTRATED PARTS

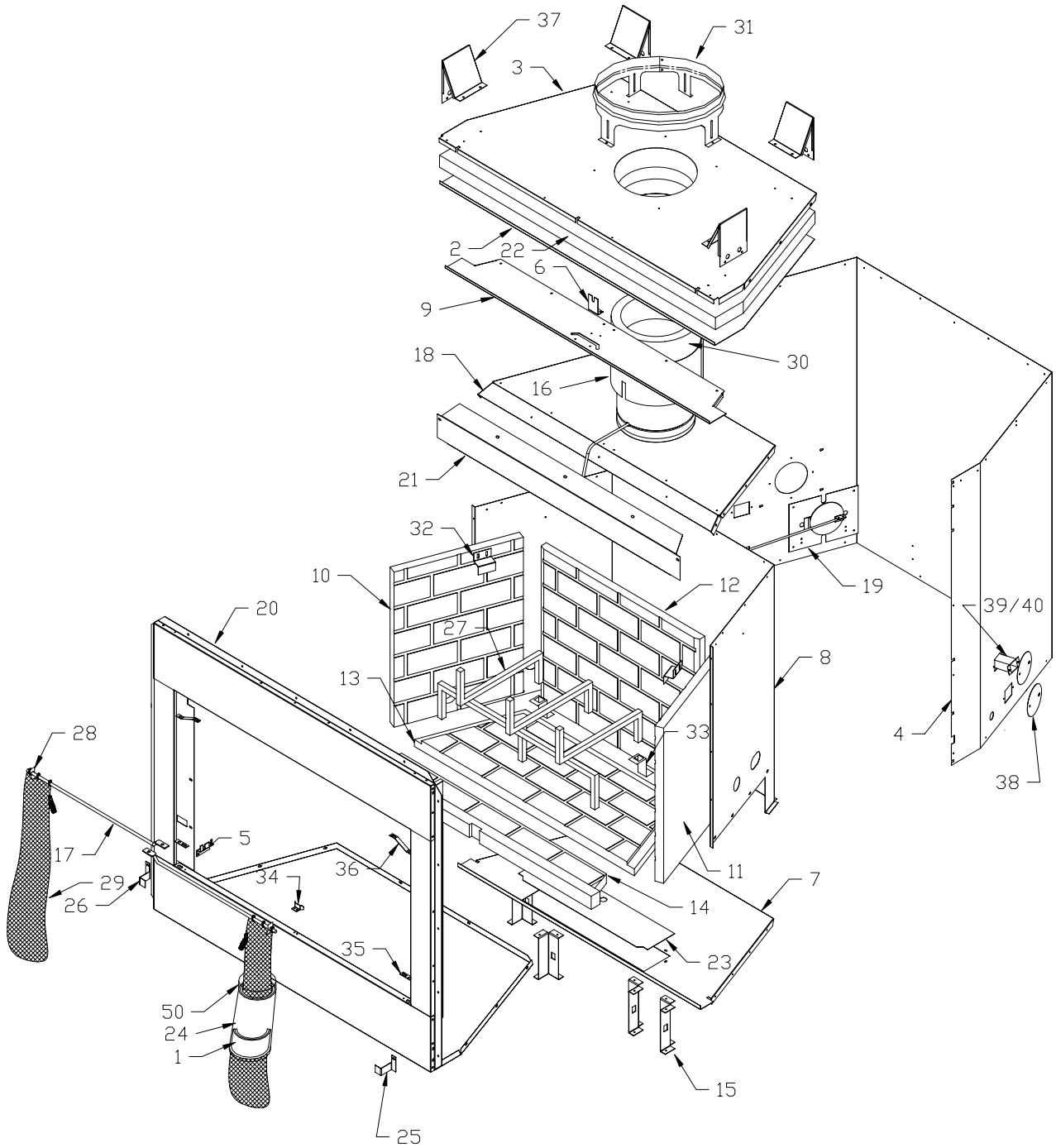

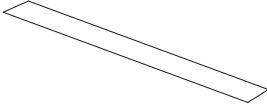
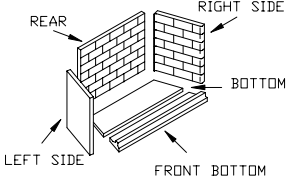
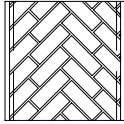
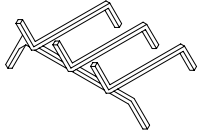

D150

REPLACEMENT PARTS

<p>EMBER PROTECTOR</p>  <p>EP-36</p>	<p>STANDARD BRICK LINER</p>  <p>HERRINGBONE BRICK LINER</p>  <p>SEE PARTS LIST ON PAGE 11 FOR PART NUMBERS</p>	 <p>GRATE PN 111028-01</p>
---	---	---

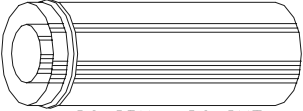
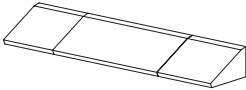
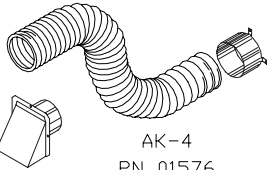
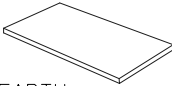
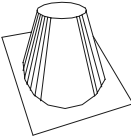
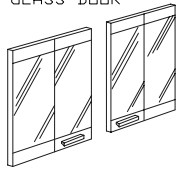
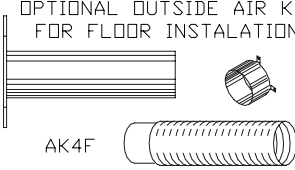
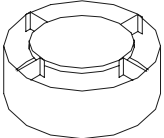
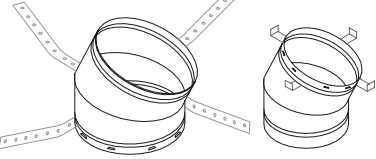
ACCESSORY PARTS

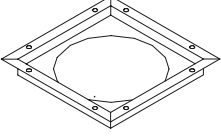
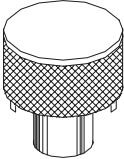
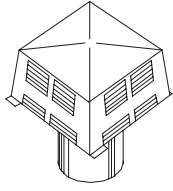
<p>DOUBLE WALL PIPE</p> <p>12-8DM 12-8HT 18-8DM 18-8HT 24-8DM 24-8HT</p>  <p>36-8DM 36-8HT 48-8DM 48-8HT</p>	<p>ADJUSTABLE HOOD</p> <p>REQUIRED WHEN INSTALLING A VENT-FRE GAS LOG IN THIS FIREPLACE</p>  <p>ANTIQUE BRASS FINISH GA6053 POLISHED BRASS FINISH GA6052 BLACK PAINTED FINISH GA6050</p>	<p>OPTIONAL OUTSIDE AIR KIT FOR SIDE WALL INSTALLATION</p>  <p>AK-4 PN 01576</p>	 <p>HEARTH EXTENSION HE-36</p>
<p>ROOF FLASHING</p> <p>0 TO 6/12 PITCH -- V6F-8DM 6/12 TO 12/12 PITCH -- V12F-8DM</p> 	<p>BI-FOLD GLASS DOOR</p>  <p>BD36 BLACK FINISH BD36B BRUSHED BRASS FINISH BD36P PLATINUM FINISH</p>	<p>OPTIONAL OUTSIDE AIR KIT FOR FLOOR INSTALLATION</p>  <p>AK4F</p>	
<p>ANTI-DRAFT SHIELD (ROUND TOP TERMINATION ONLY)</p>  <p>ADS-8DM</p> <p>30° OFFSET AND RETURN</p>  <p>30E-8DM</p>	<p>STORM COLLAR</p>  <p>SC1-1 FOR RT-8DM AND RTL-8DM SC2-1 -- USED FOR RTT-8DM AND RTTL-8DM</p> <p>FIRESTOP SPACER</p>  <p>V3600FS-8DM</p>	<p>ROUND TOP TERMINATIONS RT-8DM RTL-8DM</p>  <p>ROUND TOP TERMINATIONS WITH SLIP SECTION RTT-8DM RTTL-8DM</p>	<p>SQUARE CHASE-TOP TERMINATION ET-8DM ETD-8DM</p>  <p>ECONO-TOP TERMINATION WITH SLIP SECTION ETL-8DM ETLD-8DM</p>

D151